



WEL-TECH EQUIPMENTS PVT LTD

Plot No. 57/9, Phase 1, Nr. Kiran Industries
Vatva GIDC, Vatva, Ahmedabad, Gujarat
Pincode: 382445

Installation, Operation & Maintenance Manual For ACP Series



INDEX

- 1 - General instructions**
 - 2 - Safety instructions**
 - 3 - In case of emergency**
 - *Basic first aid*
 - 4 - Pump outlines**
 - 5 - Uncrating, lifting and moving instructions**
 - 6 - Storage instructions**
 - 7 - Mounting and alignment instructions**
 - *Pump/motor assembly mounted on a baseplate*
 - *Alignment procedure for pump/motor assembly on baseplate*
 - *Alignment instructions*

 - 8 - Electrical connections**
 - 9 - Installation instructions**
 - *Installation of pump/motor assembly*
 - *Suction and discharge piping*
 - *Suction piping*
 - *Discharge piping*
 - *Piping cleaning*
 - *Pressure testing*
 - *Accessories and auxiliary connections*
 - 10 - Check list prior to start-up**
 - 11 - Starting, operating and stopping procedures**
 - *Start-up*

 - Pump with flooded suction
 - Pump with suction lift (from well)
 - Starting a pump without back pressure at discharge side
 - Starting a pump with back pressure at discharge side

 - *Operation*
 - *Shut down*

 - 12 - Operation check list**
 - 13 - Lubrication instructions**
 - *Grease lubricated ball bearings*
 - *Oil lubricated ball bearing*
 - 14 - Packed stuffing boxes**
 - *Adjusting the packing*
 - 15 - Trouble shooting chart - problems, causes and solutions**
 - 16 - Pump repair and removal from installation**
 - 17 - Spare parts**
 - 18 - Engineering data**
 - Starting torque
 - Typical performance curves
 - Units conversion table
-

1 GENERAL INSTRUCTIONS

This manual is intended to provide reference to:

- pump safe application and operation
- pump installation and maintenance instructions
- pump start-up, operation and stopping procedures.

The pump user must complete the section at the end of this manual where the design conditions for the pump are recorded. The manual must be filed in a safe place and be accessible to the operator and to the maintenance personnel. The qualified personnel responsible for the operation or maintenance of the pump should read **CAREFULLY** the whole manual before operating or working on the pump. Qualified personnel are those with experience, knowledge and have a good familiarity with the working safety regulations. They usually have a knowledge of basic first aid.



The pump is to be used only for the applications specified on the confirming order for which WELTECH PUMPS has selected the design, materials of construction and tested the pump to meet the order specifications. Therefore the pump **CANNOT** be used for applications other than those specified on the order confirmation.

In the event the pump is to be used for different applications, please contact the sales office or representative of the manufacturer. WELTECH PUMPS declines to assume any responsibility if the pump is used for different applications without prior written consent.

The user is responsible for the verification of the ambient conditions where the pump will be stored or installed. Extreme low or high temperatures may severely damage the pump unless proper precautions are taken.

WELTECH PUMPS does not guarantee repairs or alterations done by user or other unauthorised personnel. Special designs and constructions may vary from the information given in this manual. Please contact WELTECH PUMPS should you have any difficulty.

NOTE: Drawings appearing in this manual are only schematics and not to be used for construction.

For more specific information contact the Engineering Department of WELTECH PUMPS or the authorised local representative.

2 - SAFETY INSTRUCTION



CAUTION: CAREFULLY READ FOLLOWING INSTRUCTIONS.

Strictly adhere to the instructions listed below to prevent personal injuries and/or equipment damage.

- **ALWAYS** apply the pump for the conditions outlined on the confirming order.
- Electrical connections on the motor or accessories must **ALWAYS** be carried out by authorised personnel and in accordance to the local codes.
- Any work on the pump should be carried out by at least 2 people.
- When approaching the pump **ALWAYS** be properly dressed (avoid use of clothes with wide sleeves, neckties, necklaces, etc.) and/or wear safety equipment (hard hat, safety glasses, safety shoes, etc.) adequate for the work to be done.
- Be **ALWAYS** informed on locations of first aid sites inside the company and carefully read safety and medical first aid prescriptions in force.
- **ALWAYS** stop the pump prior to touching it for whatever the reason.
- **ALWAYS** disconnect the power to the motor prior to working or removing the pump from the installation.
- **NEVER** work on the pump when it is hot.
- **DO NOT** attempt to remove the safety guards when the pump is operating.
- After completion of the work **ALWAYS** re-install the safety guards previously removed.
- **NEVER** touch pump or piping with temperatures higher than 80°C.
- **ALWAYS** be careful when handling pumps that convey acids or hazardous fluids.
- **ALWAYS** have a fire extinguisher in the vicinity of the pump installation.
- **DO NOT** operate the pump in the wrong direction of rotation.
- **NEVER** put hands or fingers in the pump openings or holes.
- **NEVER** step on pump and/or piping connected to the pump.
- Pump and piping connected to the pump must **NEVER** be under pressure when maintenance or repair is carried out.

Tab. 1

MATERIAL	USE	MAJOR RISKS
Oil and grease	General lubrication, ball bearings	Skin and eye rash
Plastic & elastomer components	O-Ring, V-Ring, splash ring	Smoke & vapours in case of overheating
Teflon & Kevlar fibbers	Packing rings	Release of dangerous powder, release of smoke if overheated
Paints & varnishes	Pump outside surface	Release of powder and smoke if working the painted areas. Flammable
Protective liquid	Pump inside surface	Skin and eye rash

3 - IN CASE OF EMERGENCY

In the event of pump break-down and/or loss of pumped fluid, immediately disconnect the electrical power to the motor and contact the responsible personnel in charge of the installation, which should intervene with at least two people paying particular attention to the fact that the pump may be handling dangerous fluids, hazardous to the health and environmentally unsafe.

After the causes for the emergency have been addressed and resolved, it will be necessary to follow the starting procedures for the start-up of the pump/motor assembly.

3.1 - BASIC FIRST AID

In the event dangerous substances have been inhaled and/or come in contact with the human body, immediately follow the instructions given in the company's internal medical safety procedures.

4 - PUMP OUTLINES

The instructions given in this manual refer to the listed below single stage and multistage centrifugal pumps, horizontal or vertical mounted.

NOTE: Capacities and pressures are approximated and refer to the maximum attainable values for pumps applied in standard conditions at room temperature.

5 - UNCRATING, LIFTING AND MOVING INSTRUCTIONS

Upon receipt verify that the material received is in exact compliance with that listed on the packing slip.

When uncrating follow the instructions listed below:

- Check that no visible damage exists on the crate that could have occurred during transport
- Carefully remove the packaging material
- Check that pump/or accessories such as tanks, piping, valves, etc. are free from visible markings such as dents, scratches and damage which may have occurred during transportation
- In the event of damage, report this immediately to the transport company and to WELTECH PUMPS customer service department.

Discard through controlled disposals all packaging materials which may constitute personal injury (sharp objects, nails).

The pump must **ALWAYS** be moved and transported in the horizontal position. Prior to moving the unit find the following:

- total weight
- centre of gravity
- maximum outside dimensions
- lifting points location.



For a safe lifting it is recommended to use ropes, or belts properly positioned on the pump and/or lifting eyebolts with correct movements, to prevent material damages and/or personal injuries. Lifting eyebolts fitted on single components of the assembly (pump or motor) should not be used to lift the total assembly.

The fig. 1 shows several additional examples of lifting.

Avoid lifts whereby the ropes or straps, form a triangle with the top angle over

90°. The fig. 2 shows several additional examples of lifting to be avoided

Prior to moving the unit from an installation, always drain any pumped fluid from the pump, piping and accessories, rinse and plug all openings to prevent spillage.

For instructions to remove the unit from installation.

6 - STORAGE INSTRUCTIONS

After receipt and inspection the unit, if not immediately installed, the unit must be repackaged and stored in the best way.

For a proper storage proceed as follows:

- store the pump in a location which is closed, clean, dry and free of vibrations
- do not store in areas with less than 5°C temperature (for lower temperature it is necessary to completely drain the pump of any liquids which are subject to freezing)



FREEZING DANGER!

Where the ambient temperature is less than 5°C it is recommended to drain the pump, piping, separator, heat exchanger, etc. or add an anti-freeze solution to prevent damage to the equipment

- fill the pump with a rust-preventative liquid that is compatible with the pump gaskets and elastomers. Rotate the shaft by hand to impregnate all internal surfaces. Drain the excessive liquid from the pump and associated piping.

Please note that the pumps with cast iron internal parts have been treated at the factory, prior to shipment, with a rust-preventative liquid: this liquid is capable of protecting the pump against rust for a period of 3 to 6 months.

A further solution, for long term storage, is to fill the pump with the rust inhibitor, rotate the pump shaft by hand to eliminate any air pockets (the liquid must be suitable with gasket, elastomers and pump materials).

- plug all openings that connect the pump internals to the atmosphere
- protect all machined external surfaces with an anti-rust material (grease, oils, etc.)
- cover the unit with plastic sheet or similar protective material
- rotate pump shaft at least every three months to avoid possible rust build-up or seizing
- any pump accessories should be subjected to similar procedure.

OK

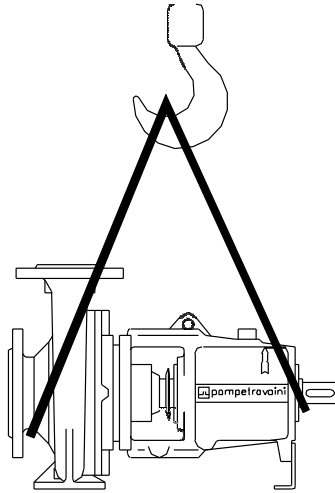

Fig. 1

NO

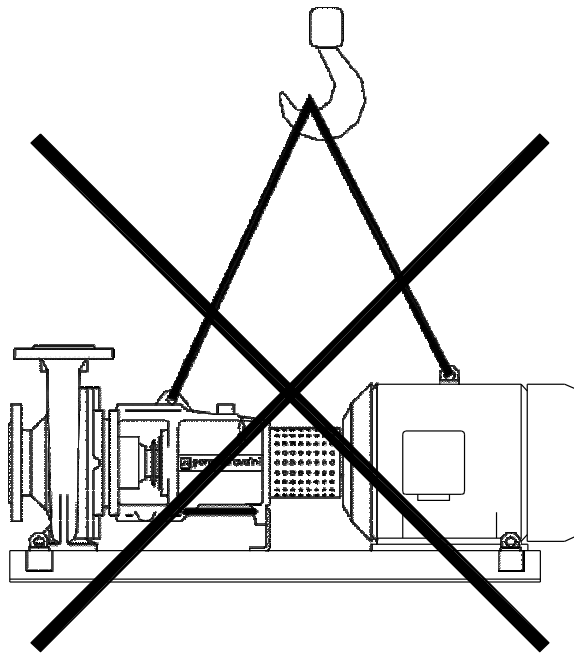

Fig. 2

7 - MOUNTING AND ALIGNMENT INSTRUCTIONS

- PUMP/MOTOR ASSEMBLY MOUNTED ON A BASEPLATE

If the pump has been furnished with bare shaft end (i. e. without motor) it is required to procure a proper baseplate on which to mount the pump/motor assembly. The baseplate must be properly designed for maximum rigidity to prevent vibrations and distortions. It is recommended the use of a fabricated baseplate manufactured with rigid "U" shaped channel (fig. 15 illustrates an example).

When the pump has been purchased without the electric motor, it is then required to select the proper motor before proceeding to the installation of the unit.

Selection of motor must consider the following data at running condition:

- maximum power absorbed by the pump over the total operating range pump operating speed (RPM)
- available power (Hertz, voltage, poles,etc.)
- motor enclosure type (CVE, AD-PE, ODP, TEFC, EX.PR.etc.)
- motor mount (B3, B5, horizontal, vertical, C-flange, D-flange,etc.).

Flexible couplings are selected considering:

- nominal motor horse power
- motor operating speed
- coupling guard must meet safety standards as dictated by EN 294, OSHA, etc.

Flexible couplings must be properly aligned. Bad alignments will result in coupling failures and damage to pump and motor bearings.

Assembly instructions for PUMP-MOTOR ON BASEPLATE are listed on paragraph 7.3 steps 7, 1, 8, 5, 9, 10, 11. For pump driven with V-BELT, please consult WELTECH PUMPS for eventual information.

- ALIGNMENT PROCEDURE FOR PUMP/MOTOR ASSEMBLY ONBASEPLATE.

The pump/motor assembly is properly aligned by WELTECH PUMPS prior to shipment.

It is however required to verify the alignment prior to the start-up. Misalignment can occur during handling, transportation, grouting of assembly, etc.

For alignment procedure of BASEPLATE DESIGN see paragraph 7.3 steps 7, 5, 9, 10, 11.

PLEASE NOTE: Coupling sizes and permissible coupling tolerances listed in this manual are applicable to the particular coupling brand installed by WELTECH PUMP as a standard. For sizes and tolerances of other type of couplings, follow the instructions given by their respective manufacturer.

- ALIGNMENT INSTRUCTIONS

NOTICE: Alignment should be done at ambient temperature, obviously with power to the motor disconnected and following the safety procedures to avoid accidental starting.

Should the pump operate at high temperatures which could upset the coupling alignment, it is necessary to check the alignment to secure proper working operation at such operating temperatures.

It is recommended the use of proper hand protections such as gloves, when effecting the operations listed below

(schematics for various assemblies are shown).

NOTE: The following points must be followed with the sequence stated above and depending upon the type of operation: alignment **assembly** or alignment **verification**.

- 1 - Thoroughly clean motor/pump shaft ends and shaft keys, place the shaft keys in the proper keyway slots and fit the coupling halves in line with the shaft ends. The use of a rubber hammer and even pre-heating of the metal half couplings may be required (see fig. 3). Lightly tighten the set screws. Verify that both pump and motor shafts rotate freely.

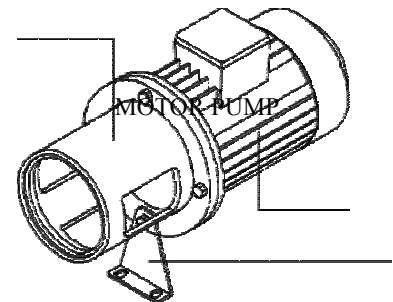
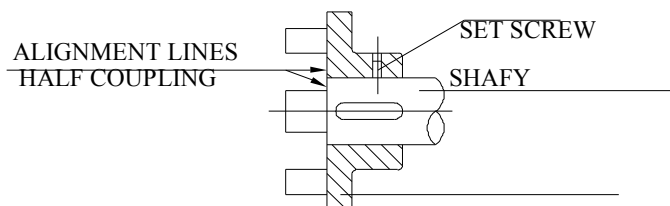

Fig. 4

2 - Insert the perforated metal sheet coupling guard inside the lantern so that the coupling is accessible from one of the lateral openings. Couple the electric motor to the pump lantern engaging the two coupling halves, hands may reach the coupling halves through the lateral opening tighten the assembly with bolts supplied with the unit and install the supporting foot, when applicable (see fig. 4).

- 3 - Applying slight hand pressure to the coupling guard, rotate it so that one opening of the lantern is accessible.
- 4 - Rotate by hand the coupling through the lateral opening of the lantern to make sure the pump is free.
- 5 - With a proper spacer check the distance between the two coupling halves. The gap value "S" should be as listed on table 2 or as given by the coupling manufacturer. In the event an adjustment is necessary, loosen the set screws on the coupling half and with a screw driver move the coupling half to attain the gap "S" (see fig. 7). Then tighten the set screw and rotate the rotor by hand to make sure, once more, that there is no obstruction.
- 6 - Rotate back the coupling guard by hand through the two openings of the lantern so that both

openings are completely covered. This will
PUMP

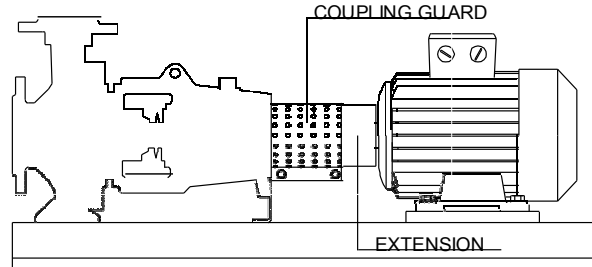

Fig. 5 - CHECKING ALIGNMENT ON BASE MOUNTED
DESIGN

7 - Remove the coupling guard and its extension (if there is one) attached to the pump, by removing the two locking screws (see fig. 5 and 6).

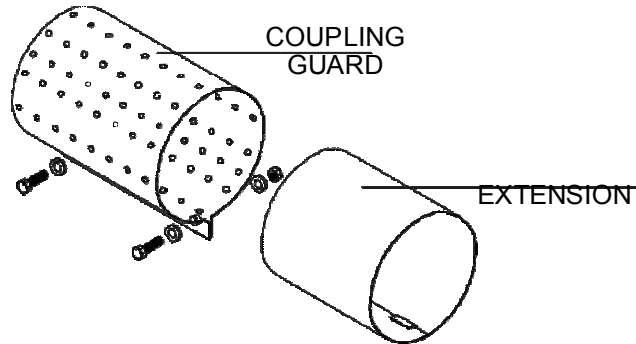

Fig. 6 - MOUNTING THE UNITS ON THE BASEPLATE

8 - Place the electric motor on the baseplate and bring the two coupling halves together with approx. 2 mm. gap between them keeping the motor axially aligned with the pump shaft. In the event the two shaft heights do not align, proper shimming under the pump or motor feet will be required. Mark the motor and/or pump anchoring bolt holes. Remove motor and/or pump, drill and tap the holes, clean and mount pump and/or motor in place and lightly tighten the bolts.

9 - With a straight edge ruler check the parallelism of the two coupling halves at several points ,90° from each other (see fig. 8).

NOTE: Easier and more accurate readings can be attained with instruments such as Dial Indicators (if readily available).

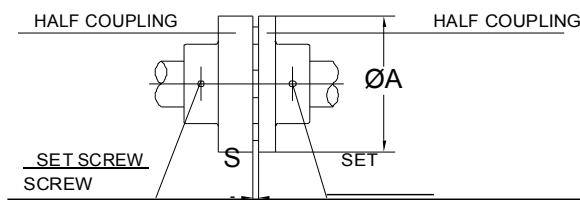

Fig. 7

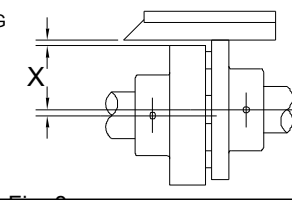

Fig. 8

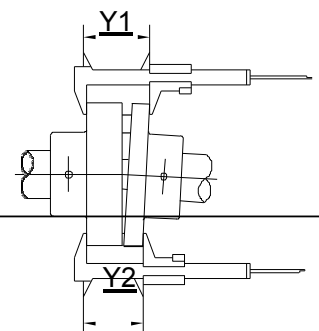

Fig. 9

If the maximum value of "X" is higher than that listed in the tab. 2 (for the given coupling size) it will be required to correct the alignment by using decimal shims under the pump or motor feet (NOTE: the optimal values have to be considered half of the reported data).
 When the measured values fall within the tolerances the pump and motor anchoring bolts can be tightened.

- 10 - Angular misalignment can be measured with a Calliper. Measure the outside coupling dimension at several points (see fig. 9). Find the minimum and maximum width of the coupling, the difference between these two readings "Y" (Y1-Y2) should no exceed the value listed in tab. 2 for the given coupling size (NOTE: the optimal values have to be considered half of the reported data). Should this value be greater it will be necessary to correct the alignment by re- shimming the pump and/or motor.
 Following this operation it is recommended to check once more the value "X" to make sure that both values are within the allowed tolerance (see point 9). Make sure that both set screws on the coupling halves are properly secured.

Tab. 2

COUPLING "Ø A" mm.	GAP "S" mm.	PARALLEL "X" mm.	ANGULAR "Y" mm.
60	2 to 2.50	0.10	0.20
80			
100			
130			
150	3 to 3.75	0.15	0.25
180			
200			

- 11 - Install the coupling guard and its extension (if applicable) on the pump, secure the two locking bolts. The gap between motor and guard should not be greater than 2 to 3 mm. (see fig. 10).

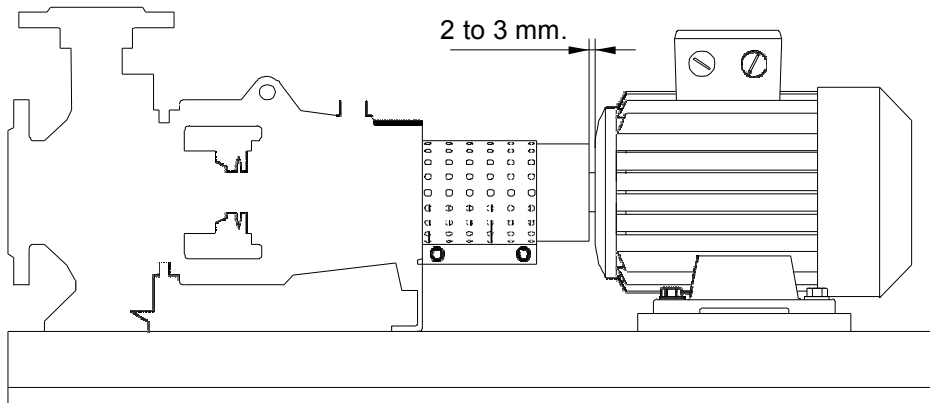

Fig. 10

8 - ELECTRICAL CONNECTIONS



Electrical connections must be made exclusively by qualified personnel in accordance with the instructions from the manufacturer of the motor or other electrical components and must adhere to the local National Electrical Code.



FOLLOW ALL SAFETY PRECAUTIONS AS LISTED IN CHAPTER 2. BEFORE DOING ANY WORK TO THE INSTALLATION DISCONNECT ALL POWER SUPPLIES.

It is recommended that electric motors and eventual connected accessories be protected against overloading by means of circuit breakers and/or fuses.

Circuit breakers and fuses must be sized in accordance with the full load amperage appearing on the motor nameplate. It is advisable to have an electrical switch near the pump for emergency situations. Prior to connecting the electrical wiring, turn the pump shaft by hand to make sure that it rotates freely. Connect the electrical wiring in accordance with local electrical codes and be sure to ground the motor.

Motor connection should be as indicated on the motor tag (frequency, voltage, poles and max consumption) and as discussed in the motor instruction manual.

It is recommended that motors over 7.5 kW be wired for Star-Delta start-up, to avoid electrical overloads to the motor and mechanical overloads to the pump.

Be sure to replace all safety guards before switching on the electrical power.

If possible check the direction of rotation before the motor is coupled to the pump but protect the motor shaft to prevent any accidents. When this is not possible briefly jog the pump to check its direction of rotation (see arrow on pump for correct rotation). If the direction must be changed two of the three electrical wire leads must be alternated with each other (at the terminal box or at the motor starter).

Please be aware that rotation in the wrong direction and/or pump running dry may cause severe pump damage.

Electrical instrumentation such as solenoid valves, level switches, temperature switches, flow switches, etc. which are supplied with the pump or systems must be connected and handled in accordance with the instructions supplied by their respective manufacturers.

9 - INSTALLATION INSTRUCTIONS

Information to determine the piping sizes and floor space requirements can be obtained from dimension drawings and other engineering data. The information required is:

- size and location of suction and discharge flanges
- size and location of all connections for flushing, cooling, heating, draining, etc.
- location and size for mounting bolts for pump and/or baseplate and/or frame.

In the event additional accessories are required to complete the installation such as separators, piping, valves, etc. refer to following chapters 9.1 - 9.2 - 9.3.

Proper lifting devices should be available for installation and repair operations.

Pump assembly should be installed in an accessible location with adequate clear and clean space all around for maintenance, so that an efficient and proper installation can be made.

It is important to have proper room around the unit for ventilation of motor. Avoid installing the unit in hidden locations, dusty and lacking of ventilation.

Pump/motor assembly should not be installed in narrow areas, dusty, toxic and explosive ambient. In the event this is

not possible it is recommended to ventilate the areas to help cooling the motor. All components used in the installation should comply with the safety codes.

Select a mounting pad that will minimise vibrations or torsion of the pump baseplate or frame. It is generally preferred to

have a concrete base or sturdy steel beams.

It is important to provide adequate anchor bolting for the pump frame or baseplate to be firmly attached to the foundations (see fig. 11).

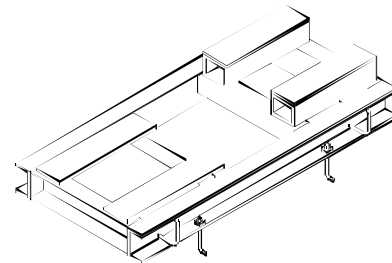
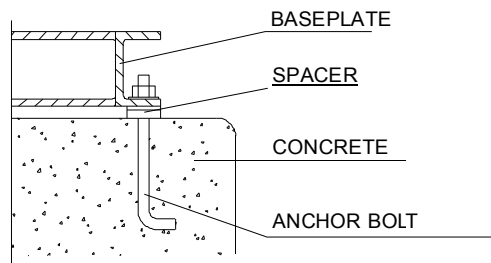

Fig
11

Concrete pads and other concrete works must be aged, dry and clean before the pump assembly can be positioned in place. Complete all the work relating to the foundations and grouting of the pump assembly, before proceeding with the mechanical and electrical portion of the installation.

- INSTALLATION OF PUMP/MOTOR ASSEMBLY

Place the pump assembly on the foundation pad aligning the anchoring bolts.

If necessary use metal spacers to level the unit and check the flange connection for good horizontal and vertical planes. Tighten the foundation bolts.

Check again the level of the assembly and proceed with the pump/motor alignment verification as discussed in

paragraph

7.2.

In cases where the pump is installed on a baseplate separated from that of the motor (due to expected piping forces, moments or as it often is in cases of large units) it is recommended to first install the pump and then proceed with the motor installation and alignment.

- SUCTION AND DISCHARGE PIPING (see fig. 12)

Identify first locations and dimensions of all connections required to interconnect the pump with the installation, then proceed with the actual piping: connect the pump suction and discharge flanges, the service liquid line and all other service connections.



BE SURE TO PIPE THE CORRECT CONNECTION FROM THE INSTALLATION TO THE RESPECTIVE PUMP CONNECTION !

To prevent foreign matters from entering the pump during installation, do not remove protection cap from flanges or cover from openings until the piping is ready for hook-up.

Inlet and discharge piping should be of same size as the pump flanges, where possible increase the pipe size but

NEVER decrease the size.

In general the liquid velocity in the suction piping should not exceed 2 m/s and in the discharge piping should be less than 3 m/s. Higher liquid velocities will result in higher pressure drops which could create cavitation in the suction piping and excessive pressure losses in the discharge piping, which would negatively affect the system performance and the pump.

Where possible, avoid using piping turns and especially short radius elbows.

When using larger pipe sizes than the nominal, the reduction from a larger diameter to a small diameter should be gradual and with conical configuration, the length of the conical area should be 5 to 7 times the difference in size of the two diameters.

Piping should always be supported to neutralise any forces, moments, piping weights, thermal expansions, etc. which could create pump/motor misalignment, deflections and overloading to foundation bolts. Pipe joints should be by means of flanges with flange gaskets of proper size and material.

Flange gaskets should be properly centred between the flange bolts so that there is no interference with the flow of the liquid.

There should not be any tensions, deformations or misalignment of the piping when loosening the bolts holding the flanges together.

Any thermal shocks and/or excessive vibrations should be controlled by means of expansion joints, flexibles, etc. having same size as the piping.

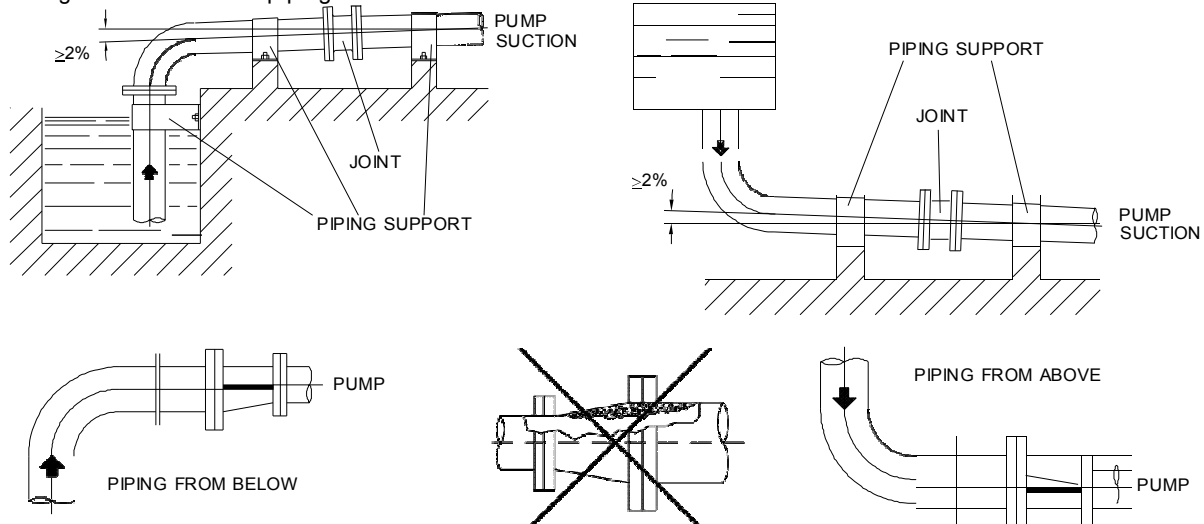

Fig. 12

- **Suction piping** (see fig. 13)

To prevent losing pump priming absolutely avoid formation of air pockets in the suction piping. This piping therefore should have a slope toward the reservoir in the case of suction lift installation, and toward the pump in the case of the flooded suction installation.

Isolating valve should only be on the fully open or fully closed positions and **NEVER** as a flow regulator. The valve should be installed with the stem in the horizontal position relative to the flow in the piping and at a distance from the pump suction flange of at least 10 times the pipe size.

Depending upon the application, a non return valve or a foot valve should be fitted in the suction piping, a strainer or

filter will prevent solids from entering the pump and a pressure or vacuum gauge will enable reading the pump inlet pressure.

All components listed above will create pressure drops which must be taken into consideration in the design stage.

Where more than one pump is installed, every pump should have its own separate suction piping; if a stand-by pump is installed the two inlets can be connected to a common manifold with a single suction piping.

- **Discharge piping** (see fig. 13)

Right after the pump discharge flange install a non return valve will stop dangerous water hammer which could seriously damage the pump discharge casing, a flow regulating valve (Globe or Needle valve), a pressure gauge can be connected to the threaded connection under the pump discharge flange, a vent valve should be fitted in this piping to fill pump and piping for initial start-up.

- **Piping cleaning**

Before installation start-up clean piping and any reservoirs removing loose materials and foreign particles.

Particular attention for cleaning should be for installations where welding of piping and components has taken place.

- **Pressure testing**

When the installation has been completed it is necessary to test the piping for both static pressure and vacuum. Testing should be carried out in accordance to the applicable standards for the piping function and the operating pressures.

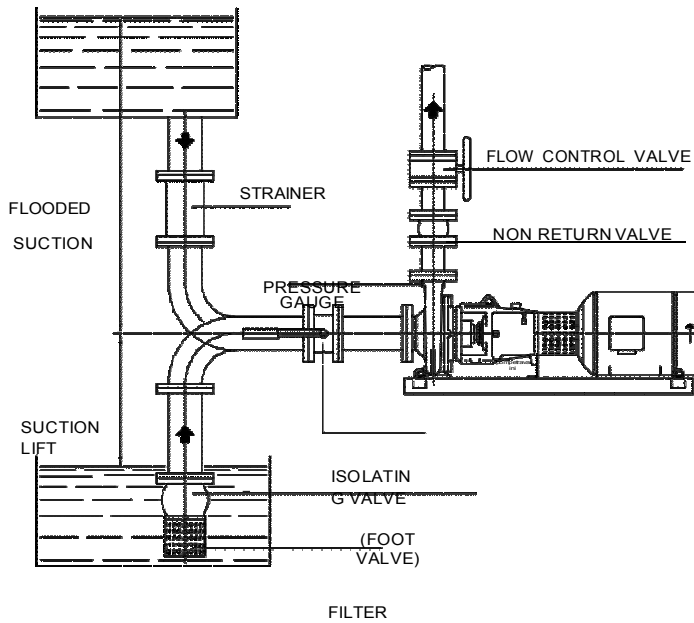

Fig.13

Pump series ACP

- ACCESSORIES AND AUXILIARY CONNECTIONS

Depending on the application accessories may be installed to test the pump performance (instrumentation to measure pressure, temperature, capacity, etc.) and/or for necessary operations (cooling, heating, flushing of seals, etc.).

When accessories are required the following should be considered:

- a) Pressure and vacuum gauges must be properly anchored and connected at the measuring points located at pump flanges or near the flanges, using approx. 8 mm. diameter tubing with "pig tail" configuration to alleviate pressure fluctuations.
For safety purposes, isolating and vent valves should be fitted before these instruments (see fig. 14).

- b) Temperature gauges should be installed with thermowells selected for the specific purpose and fitted in strategic locations where the reading is required (see fig. 15).

- c) Every pump is fitted with draining connections at the pump casing.
If required, pump drain and mechanical seals leakages can be piped to a container located nearby on the floor or (if available) to the drain catch basin for the total installation.
The pump draining piping should be fitted with an isolating valve and both should be suitable for the pumps maximum operating pressure.

- d) Cooling, heating, flushing of mechanical seals and other piping must be connected only to the designated connections located on the pump (see fig. 21).

All tubing and connections must be a minimum of same size as the connection on the pump.

Insulation, if required, must be limited to the pump body, leaving all other components such as bearing frame and motor uncovered for heat dissipation.

- e) Controlling the minimum capacity.

When the pump operates near the shut-off with almost no flow, almost all the motor power is transformed into thermal energy which is absorbed by the pumped liquid.

If the capacity is less than the minimum recommended (10-15% of pump capacity at its best efficiency point) not only will there be excessive load on the pump support and bearings but the liquid could evaporate resulting in damage to the impellers and wear rings with possibility of the pump seizing.

To prevent these problems it is recommended the installation of a minimum flow valve in the discharge piping, right after the pump but before the flow regulating valve.

In the event the flow regulating valve being excessively throttled or even completely closed, there will always be the

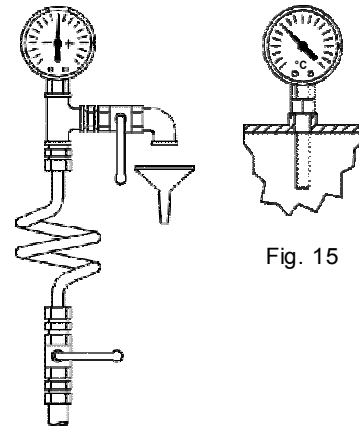

Fig. 15

Fig. 14

required minimum liquid flow recirculated from the pump discharge to the suction piping of the pump.

The other device which may be fitted in this by-pass line (from pump discharge, before flow regulating valve, to pump suction) is a calibrated orifice sized for the minimum liquid flow required by the pump.

- f) To prevent pumps running dry it is recommended to install, in the pump discharge line, a flow meter to check that there is a constant liquid circulation in the piping.
- g) Fitting of a power meter will help analyzing the operation of the pumps. Knowing the minimum and maximum power absorbed by the operating pumps will help identifying problems that may be caused by dry running, siphoning, etc.
- h) Accelerometers fitted on the bearing housing near the bearings, will help with the reading of the vibrations. An analysis of the vibration diagram, direct or indirect, would provide a diagnostic to prevent mechanical breakdowns, such as hydraulic cavitation.

LEGEND for figures 16

- d1.1 Threaded connection - "double tandem" mechanical seal flushing inlet from outside
 - d1.2 Threaded connection - "double tandem" mechanical seal flushing outlet
 - d2.1 plugged connection - mechanical seal chamber cooling liquid inlet
 - d2.2 plugged connection - mechanical seal chamber cooling liquid outlet
 - d3.1 Threaded connection - flushing liquid inlet from outlet for "double back to back" mechanical seal or for single mechanical seal construction
 - d3.2 Threaded connection - "double back to back" mechanical seal flushing liquid outlet
 - d4.1 Threaded connection - casing heating chamber liquid inlet
 - d4.2 Threaded connection - casing heating chamber liquid outlet
 - d4.3 Plugged connection - casing heating chamber liquid drain
 - d5 Plugged connection - for manometer
 - d6 Plugged connection - for pump casing drain
 - d7.1 Threaded connection - packing seal flushing liquid inlet from outside
 - d7.2 Threaded connection - packing seal flushing liquid outlet from outside
 - d8 Plugged connection - bearings oil drain from housing
 - d9 plug with dipstick for bearings oil filling into housing
 - d10 Constant level oil filler (on request only) or oil level gauge (standard)
 - d11 Threaded connection - mechanical seal flushing liquid inlet from outside
 - d12 Plugged connection - air-hole mechanical seal chamber
 - d13 Plugged connection - sludge discharge from mechanical seal chamber
 - d14 Plugged connection - tank liquid discharge (only for TCD/2-SP)
 - d15 Threaded connection - for tank (only for TCD/2-SP)
 - d16 Threaded connection - to check oil leaks from bearing
-

Fig. 16 - CONNECTIONS AND HOOK-UPS FOR FLUSHING

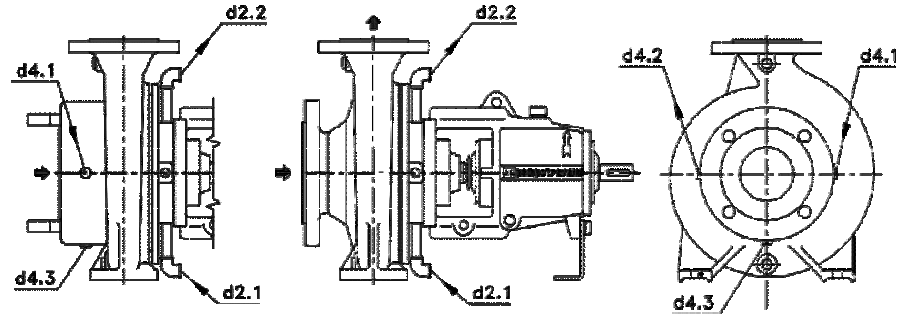
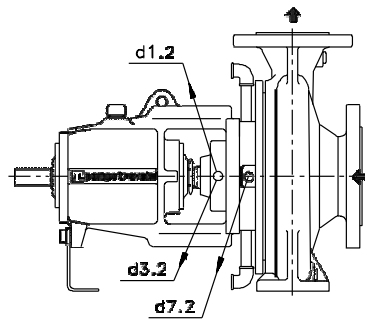
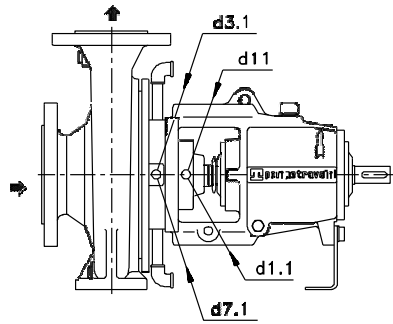

Pump series ACP - Connections as above

Pump series ACP - Connections as above

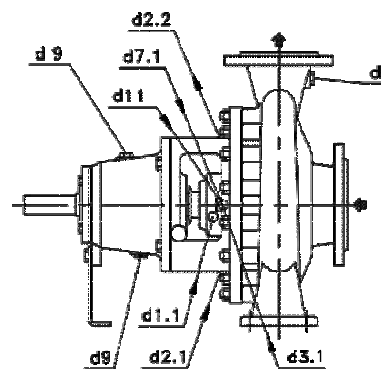
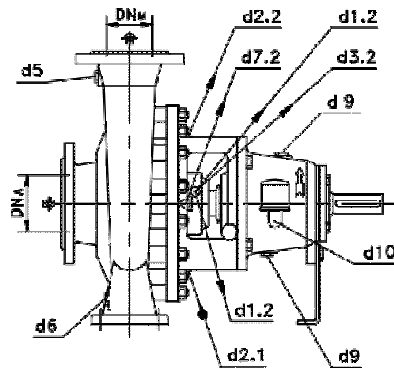

Pump series ACP - Connections as above

Fig. 17 - CONNECTIONS AND HOOK-UPS FOR FLUSHING

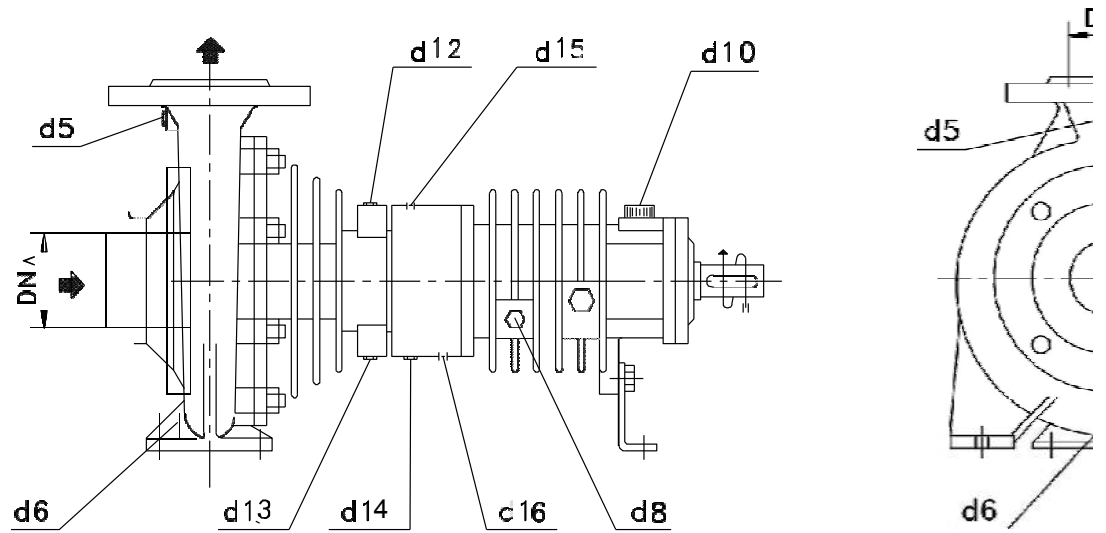

Pumps series ACP - Standard hook-ups and connections

10 - CHECK LIST PRIOR TO START-UP



All questions listed below must have **POSITIVE** answers prior to proceeding to the pump start-up. (The following list may not be complete for special installations which may require further precautions as the cases dictate).

- This manual has been completely read, including the following chapters, and has been fully understood?
- The piping system has been flushed of any foreign particles, welding impurities, etc.?
- Have all piping and pump obstruction been removed?
- All connections and piping are leak proof and there are no external forces or moments applied to the piping or pump flanges?
- Pump and motor are properly lubricated, if required?
- Pump/motor alignment has been checked?
- If mechanical seal requires flushing has this been connected?
- All valves in the installation are in the correct position?
- All safety guards are in place?
- Has this pump's direction of rotation been checked by jogging the motor?
- The pump Stop switch is clear and visible?
- Are pump and installation ready for start-up?

11 - STARTING, OPERATING AND STOPPING

Upon receipt and/or completion of installation, before turning on the power to the electric motor, rotate the pump shaft by hand to make sure that the pump rotor is free. In the event the shaft does not turn, try to free it up by applying a torque to the pump coupling with a pipe wrench.

In the event the pump does not become free with the above procedures, fill up the pump with a suitable solvent or lubricating liquid, let it rest for several hours to allow softening of the rust build-up inside the pump, drain the pump and apply torque to the pump shaft as described above to finally free the rotor.

NOTE: The selected solvent or lubricating fluid must be compatible with the pump, seals and gasketing materials. New pumps from the factory and pumps coming from long term storage are likely impregnated with a rust preventative liquid; before the start-up, these pumps should be subjected to fresh water rinsing for approximately 15 minutes. The liquid mixture coming out of the pumps should be collected to safeguard the environment, this liquid should be sent for treatment as a special liquid.



CHECK PUMP-MOTOR COUPLING ALIGNMENT!

This must be done prior to the first start-up and before every start-up if pump or motor has been removed from the installation for maintenance or other reasons.

- START-UP

Never run the pump when it is dry!

Before starting-up verify that all auxiliary supplies are in place, ready to be used and, where necessary, they have been correctly opened. (Example: seal or packing flushing, pressurising buffer liquid to "back to back" double mechanical seals, etc.). Make sure the pump and motor bearings have been properly lubricated and oil levels are correct.

If necessary oil topping should be done through the proper connections (see fig. 21) and with recommended lubricants. If the liquid to be handled is at dangerous high temperatures it is required to insulate the pump and the piping to prevent direct contact, the pump should also be protected against thermal shocks by insulation, preheating, etc.

Prior to starting, the suction piping and the pump must be filled with the liquid to be lifted; for this purpose there are three types of installations to be identified:



WARNING!:

During the following operations it is particularly important to avoid contact and/or inhale of eventual spilled liquid (vapour): therefore all safety precautions must be taken.

For this purpose there are three types of installations to be identified:

- Pump with flooded suction

Close the valve at pump discharge side, fully open the valve at pump suction side and the vent valve including any breather valve on the stuffing box.

NOTE: Pump series ACP are fitted with a vent cock (see fig. 16) which should be open to prevent forming air pockets

in the mechanical seal chamber. Be sure to do this only when the spilled thermal oil is at ambient temperature! When the thermal fluid exits the air cock without any air or gas bubbles, even after turning the pump rotor it

means that the whole pump is full of liquid, therefore close the air cock.

- Pump with suction lift (from well)

In this case the pump must be primed: fully open the isolating valve in suction piping.

If the pump is self-priming and it has been previously filled with liquid, there will be no problems, because the pump will be able to prime itself and lift the liquid as soon as it starts operating.

If the pump is not self-priming, but the suction piping is fitted with a foot valve, the suction piping and the pump can be

filled with liquid by opening the valve at the discharge side (provided the discharge piping is full of liquid) or fill the pump body as well as suction piping, with the liquid to be pumped, through the vent valve.

For non self-priming pumps with the suction piping not having a foot valve, the suction piping and the pump can be filled

with liquid by hooking-up the vent valve to a vacuum pump or vacuum source and keeping closed the valve at the discharge side of the pump, when the liquid exits the vent valve it means that the pump and suction piping are completely full of liquid.

At this point the vent valve should be closed and the vacuum pump (or source) can be turned off.

Check the position and/or control the opening of the minimum flow valve, flushing lines and/or auxiliary supply lines. After the pump and its suction line is full of liquid the pump should be started. In this regard there are two possible cases:

- Starting a pump without back pressure at discharge side

For centrifugal pumps type ACP motor must be started with discharge valve closed.

When the motor has reached full speed, the discharge valve can be opened until the required differential pressure is reached (CAUTION: do not operate the pump with closed discharge piping for an extended period of time, to avoid overheating problems previously discussed).

- Starting a pump with back pressure at discharge side

In this case a non-return valve must always be installed in the discharge piping.

The unit is started with the discharge valve partially open and after the pump pressure exceeds the back pressure in the discharge line then is time to adjust the discharge flow regulating valve to attain the operating pressure.

For the Starting Torque of the pump

OPERATION

After starting the pump the following should be checked:

- The differential pressure and the capacity are as expected (if required, adjust the flow regulating valve at the pump discharge side but **NEVER** throttle the valve at the suction side).
- The motor amperage does not exceed the value shown on the motor nameplate.
- The pump/motor assembly does not have unusual vibrations and noises.
- The seal arrangement works as it should:
 - if the sealing is by packing there should be continuous dripping from the stuffing box. if the sealing is by mechanical seal there should not be any leakage.
- the bearing support temperature, at full operation, is less than approx. 85°C.



NEVER OPERATE THE PUMP DRY!

If at start-up there are suspicions of abnormal operation it is recommended to stop the unit and investigate the causes.

- SHUT DOWN

The centrifugal pumps can be shut down by switching off the power to the motor, with open or closed flow regulating valve: however if there are no provisions against liquid hammer it is recommended to close the flow regulating valve at pump discharge prior to stopping the pump.

Avoid the use of instantaneous shut-off valves, such as solenoid valves. These can cause severe pump damage.

If the piping has not been fitted with non-return valves it is required to close the shut-off valves in sequence to prevent emptying the piping.

Close first the isolating valve at discharge and then at suction side.

If the non return valve is not fitted, or the isolating valve at the discharge side is not completely closed, it may happen that during the shut-down the pump shaft will rotate in the opposite direction than is normal: in such cases absolutely avoid restarting the pump until the pump shaft has stopped rotating.

Following pump shut down it is required to close any auxiliary lines such as flushing, heating, etc.

After the first start-stop and if necessary, check pump/motor alignment and make sure that no external forces or moment rest on pump or piping.

In the event the pump is shut down for an extended period of time it is recommended to completely drain the pump to prevent the possibility of freezing in the winter time and/or the possibility of corrosion due to stagnant liquid left in the pump.

12 - OPERATING CHECK LIST

Periodically check the good working condition of the pump by reading the instruments such as gauges, amp meters, flow meters, etc., the pump should constantly be performing as the installation requires.

The operation of the pump should be without abnormal vibrations or noises, if any of these problems is noticed, the pump should be stopped immediately, search for the cause and make the necessary corrections.

It is good practice to check the pump/motor alignment, the running conditions of the bearings and of the mechanical seals at least once a year, even if no abnormalities have been noticed.

If there is a deterioration of the pump performance, which is not attributable to changes in system demands, the pump must be stopped and proceed with necessary repairs or replacement.

When the pump is fitted with auxiliary supply lines such as cooling, heating or flushing it is recommended to periodically check their flow, temperature and pressure.

Please contact WELTECH PUMPS if there are doubts regarding abnormal temperature rises.

13 - LUBRICATION INSTRUCTIONS

Pumps often operate in severe conditions and the bearings are subject to relevant radial and axial forces. For a good pump operation it is therefore very important to keep the pump bearings well lubricated and clean.

WARNING: The maintenance must be carried out with the pump turned off and the electrical power, or other driving mechanism, must be disconnected. The power should only be turned back on by the same person doing the maintenance. It is however recommended to have at least a team of two workers doing the maintenance and the supervisors should be fully aware of the work in progress.



CAREFULLY FOLLOW THE SAFETY PROCEDURES LISTED IN CHAPTER 2.

Bearings and lubricants must be free of any foreign particles such as dirt, dust, etc. which could cause the bearings to seize.

See "Disassembly and assembly instructions" for bearing sizes , quantity and type of lubricants.



- GREASE LUBRICATED BALL BEARINGS.

CIP1 pump series are fitted with regreasable bearings and grease type "EP 3".

The grease applied at time of pump assembly is usually suitable for approx. 1500 to 2500 hours of operation.

It is important to remember not to overlubricate the bearings, excessive grease will lead to overheating of bearings.

It is preferred that every 1500 to 2500 hours of operation the bearings be cleaned of old grease and the bearing gage be refilled with new suitable grease.

It is necessary to carry out the greasing and maintenance operations as per the above description for the pumps with roller bearing fitted on the drive end.

Bearing temperature should not exceed 85°C in normal conditions and ambient temperatures.

Overheating could be caused by excessive grease, coupling misalignment, excessive vibrations and /or bearing wear

- OIL LUBRICATED BALL BEARINGS.

Pump series ACP are fitted with oil lubricated ball bearings.

It is good practice to replace the lubricating oil used at time of testing. Oil should also be changed after the first 50 to 100 hours of operation.

The lubricating oil, poured through the hole which is also the dipstick seat

or vent plug located at the top of the bearing frame should, as a maximum, cover the bearing balls of the lower crown (the oil dipstick or the oil level gauge show the correct quantity, see fig. 19).

The installation of a constant level oil-filler (as option) consents a correct lubricating oil level in the avoiding recurrent fillings.

For the first filling proceed as follows:

- remove vent plug of the bearing frame
- upset the oil-cruet
- pour oil into the bearing frame through the hole of plug till you can see oil in the oil-filler elbow
- fill the oil-filler pouring oil directly into the oil-cruet and NOT into the elbow (see fig. 18)
- replace the cruet in normal position
- let oil flow into bearing frame
- repeat operation till the oil level in the cruet cease to decrease.

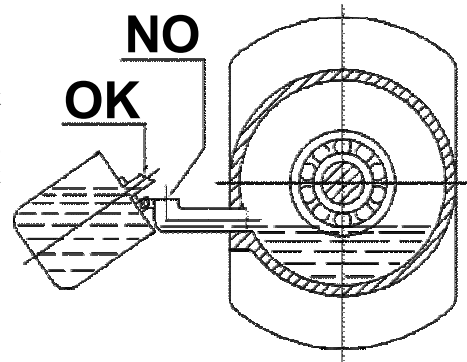

Fig. 18

The following fillings should be done pouring oil directly into the cruet and NOT into the elbow of the oil-filler or bearing frame plug (see fig. 18).

If there are no particular dangers of oil contamination (dust, water) and the temperature in the bearing frame oil bath does not exceed 60°C, oil should be changed every 4000 to 6000 hours of service.

For higher operating temperatures and contaminated oil the frequency of oil changes should be increased. Bearing temperature should not exceed 85°C in normal conditions of operations and ambient temperatures. Overheating could be caused by too much oil, coupling misalignment, excessive vibrations and/or bearing wear.

It is recommended to periodically check the oil pH which will indicate the oil stability and the oxidation grade (consult the supplier for the acceptable values).

Satisfactory oils are those with a viscosity at 40°C between 46 and 100 centistokes.

Oils with high viscosity (100 centistokes) are recommended for applications with high operating temperatures. Pumps of series NTCIP can use oils with viscosity up to 220 centistokes.

Some oil types are:AGIP OTE 55 EP AGIP BLASIA 68

CASTROL HY SPIN VG 46

ESSO TERESSO 68

NOTE: Avoid mixing different oil brands and with

different characteristiCASTROL HY SPIN AWS 68

ESSO NURAY 100

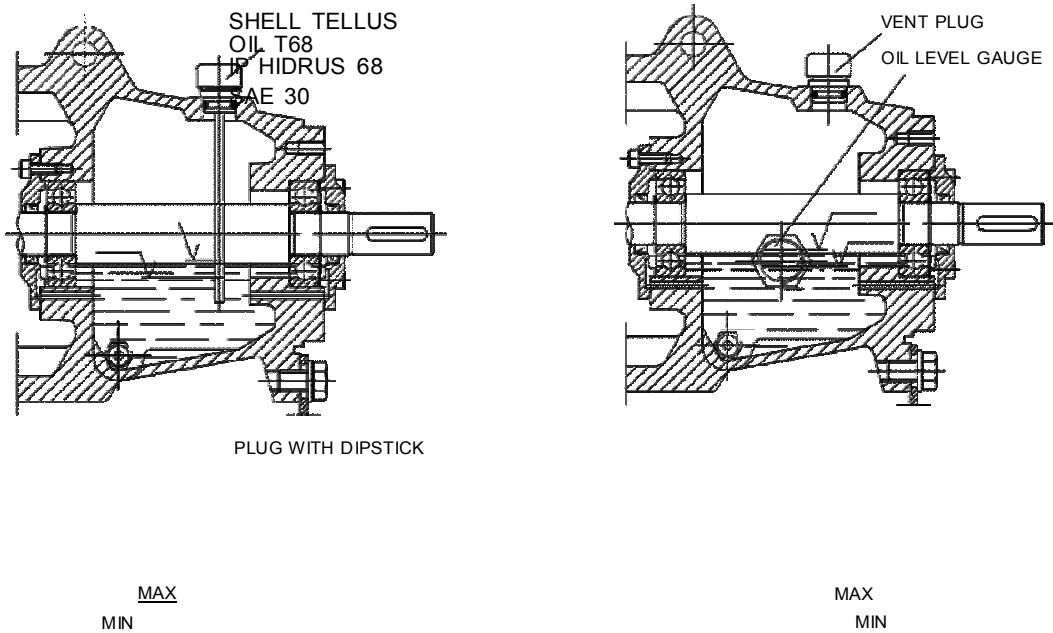

Fig. 19

14 - PACKED STUFFING BOXES

Pumps fitted with packed stuffing boxes require packing flushing either from an external source or directly from the pumped media through pump internal passages.

This liquid is necessary to remove the friction heat generated between the shaft and the packing. The dripping quantity is a function of the pump size and of the pressure in the stuffing box housing.

In any event the liquid drops coming out of the stuffing box should not exceed a temperature of 60 - 70°C in relation to handling a liquid at ambient temperature.

14.1 - ADJUSTING THE PACKING.

All adjustment operations must be performed with the **PUMP NOT RUNNING** following the safety measures given in chapter 2. After completion of the work **ALWAYS** re-install the safety guards previously removed.

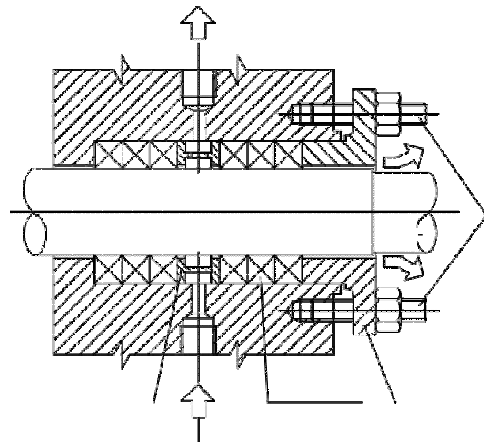

At first start up loosen the nuts of the packing gland allowing a steady flow of liquid to drain out (see fig. 20). After obtaining a steady flow of leakage gradually tighten the gland nuts until attaining a steady dripping within the limit of the above recommended temperature.

A few hours time span may be required to establish a steady dripping at low temperatures.

Packing adjustment is required when the liquid leakage increases.

When adjustment is no longer possible, the packing material should be replaced with new one.

Follow the "Disassembly and Assembly Instructions" to replace the packing materials.

In the event the pump remains out of service for more than 2 months it is recommended to replace the packing rings, prior to start-up.

15 - TROUBLE SHOOTING CHART - PROBLEMS, CAUSES AND SOLUTIONS

Consult the following table when problems are experienced, if solutions are not found in this chart (tab. 5) or should there be any doubts, do not hesitate to contact WELTECH PUMPS or your local representative.

Tab. 5 - LIST OF PROBLEMS

PROBLEM	LIST OF POSSIBLE CAUSES
Lack of, or no flow and/or pressure	1 - 2 - 3 - 4 - 5 - 6 - 7 - 8 - 9 - 10 - 11 - 12 - 13 - 14 - 17 - 25 -
Excessive flow and/or pressure	15 - 16 - 17 - 18
High power consumption	10 - 15 - 16 - 18 - 19 - 20 - 21 - 22 - 23
Excessive vibration and noise	8 - 18 - 19 - 20 - 23 - 24 - 25 - 26 - 27 - 28 - 36 - 37 - 40
Bearing overheating	19 - 20 - 28 - 29 - 30 - 36 - 38 - 39 - 42
Sealing malfunction	28 - 31 - 32 - 33 - 34 - 35 - 40 - 41

	CAUSES	SOLUTIONS
1	Pump is not primed	Repeat the priming procedure
2	Rotational speed is not adequate	Increase the motor speed in relation to the working conditions - Replace impeller with one having larger
3	Installation requires higher pressure than expected	Increase operating speed, if possible, (see point 2) or replace impeller with one of larger diameter - Change the pump or increase the number of stages in case of multistage pumps - Reduce the system pressure
4	Wrong direction of rotation	Change the motor direction of rotation
5	There are air pockets in the suction line	Modify the layout of suction piping
6	Air enters the suction line	Check the piping sealing areas
7	The pumped liquid is emulsified with air	Install a reservoir or tank before the pump to de-aerate th
8	The suction lift or/and suction pressure is more than anticipated and therefore the pump cavitates	Reset the suction lift to the original value - Increase the piping diameter - Check the suction piping, the foot valve or non return valve, the filter - Open completely the isolating valve in the suction piping - Decrease the friction losses
9	The wear ring and/or impeller neck and/or the impeller and/or the diffusers are worn out or damaged	Overhaul the pump replacing and/or repairing the damaged components
10	Viscosity, density, or specific weight of liquid have higher values than	Re-establish the characteristics of the liquid as originally expected (if necessary contact WELTECH
11	Suction piping is not sufficiently	Increase the depth of piping or foot valve in the liquid
12	Impeller is plugged with scale deposit and/or foreign materials	Take out the impeller, clean it, free the vanes and cavities of any materials - Soften the pumped liquid
13	There is entrained air in the system	Adjust the packed stuffing box or repair/replace the mechanical seal
14	Piping is plugged	Clean piping and valves - clean the filters
15	Velocity is too high	If possible, decrease the pump rotational speed
16	The required pressure of system is lower than anticipated	Adjust the flow regulating valve in discharge piping - Decrease the impeller diameter (contact WELTECH PUMPS) -
17	Pump is not suitable for the application	Contact WELTECH PUMPS
18	Inlet pressure is too high	Reduce the pressure, but without adjusting the isolating valve at the suction side
19	Pump/motor coupling is misaligned	Realign the coupling
20	Bearings are defective or worn out	Replace bearings
21	The power supply voltage is wrong -	Change the motor - Correct the power supply
22	The packing is too tight	Loosen the nuts of the packing gland
23	Pump seizing is experienced	Stop the pump and look for any rotor obstructions
24	The pump and/or piping are loose	Torque the bolts as required
25	Pump is worn out or damaged with excessive internal	Overhaul the pump
26	The coupling rubber inserts are worn	Replace the coupling inserts
27	The impeller is out of balance due to wear, deposits and encrustation	Disassemble, clean, balance and/or replace the impeller - Soften the liquid
28	Forces, moments and piping misalignment are loading the	Realign and support the piping

29	Oil level in bearing frame is low, oil quality is inadequate or there is lack of grease	Replace oil or grease to the normal level using proper quality lubricants
30	The power absorbed is too high	Decrease the power consumption by identifying the cause
31	Pump is running dry	Reinstate the correct working conditions
32	Pumped liquid or the flushing liquid to the seals is dirty and/or not	Install a filter in the flushing lines - Change flushing fluid
33	There are excessive shaft vibrations and deflections	Identify the causes and reinstate the correct working conditions
34	The pumped liquid is not adequate for the seals	Contact WELTECH PUMPS
35	The shaft sleeve is worn out	Replace the sleeve with a new one
36	The pumped flow is less than the minimum required	Increase the flow - Adjust the by-pass recirculating valve or lines
37	Baseplate or pump foundation is not adequate	Change or reinforce the baseplate and/or foundation following the recommended procedures
38	Too much grease in the bearings	Remove excessive grease and check the bearings
39	There is water in the bearing frame	Change bearings and replace all the lubricant
40	Incorrect assembly after pump repair	Overhaul pump and assembly following correct procedures
41	The mechanical seals are damaged	Remove the mechanical seals, overhaul or change them
42	The axial forces are too strong	Check the impeller

- PUMP REPAIR AND REMOVAL FROM INSTALLATION

Should the pump require repairs it is recommended to be familiar with the procedures outlined in the “Disassembly and Assembly Instructions”.



RESPECT THE SAFETY PRECAUTION MEASURES OUTLINED IN CHAPTER 2.

In any case, before working on the pump it is important to:

- procure and wear the proper safety equipment (hard hat, safety glasses, gloves, safety shoes, etc.)
- disconnect the electrical power supply and, if required, disconnect the electrical cables from the motor
- close the pump inlet and outlet isolating valves
- let the pump cool down to ambient temperature if is pumping hot liquids
- adopt safety measures if the pump has been handling dangerous liquids
- drain the pump body of the pumped liquid, through the draining connections, if necessary rinse with neutral liquid.

To remove the pump and the motor from the installation proceed as follows:

- remove bolts from pump suction and discharge flanges
- remove the coupling guard
- remove the spacer of the coupling, if there is one
- if required, remove motor by removing the bolts on the baseplate, for base mounted assembly,
- remove the pump anchor bolts on the baseplate
- remove the pump from installation without damaging other system components.

When the pump has been repaired, re-install following the steps from “Assembly and Alignment” procedures and after (see the applicable chapters starting from chapter 7).

17 - SPARE PARTS

When ordering the pump it is good practice to also order the necessary spare parts, especially when there are no stand-by pumps in the installation. This will minimise unnecessary down times in the event of pump failure or routine maintenance.

For better parts management, the VDMA 24296 standards suggest to stock the number of parts in function of the number of pumps being used by the plant (see following table).

Components		Spare parts		Number of spare parts				
Suction and discharge elements		1	1	2	2	2	3	30%
Impellers				1				
Radial seal rings		2	2	2	3	3	4	50%
Ball or roller bearings								
Shaft complete with keys, nuts, shoulder rings, etc.		1	1	2	2	2	3	30%
Bushes								
Shaft protection sleeves		2	2	2	3	3	4	50%
Neck rings		1	1	2	2	2	3	30%
Packing rings		16	16	24	24	24	32	40%
Gaskets for pump casing (Set)		4	6	8	8	9	12	150%
Other gaskets (Set)							10	100%
Mechanica - seals	Rotating part	2	3	4	5	6	7	90%
	Stationary part							
	Rotating part gasket							
	Stationary part gasket							
Springs		1	1	1	1	2	2	20%
Bearing housing groups complete with shaft, bearings, covers, seal rings, etc.		---	---	---	---	---	1	2
Coupling inserts (Set)		2	3	4	5	6	7	75%

On the pump nameplate there are printed pump model, year of manufacture and pump serial number. When ordering spare parts always provide this information.

Pump type, parts item number (VDMA) and description per the pump sectional drawing and parts list is useful information which helps to supply correct spare parts for your pump.

We recommend the use of original spares: in case this is not respected, WELTECH PUMPS declines any responsibility for eventual damages and not correct running caused by not original spare parts.

18 - ENGINEERING DATA

- STARTING TORQUE

Starting torque of a centrifugal pump is very low. Usually standard electric motors may be safely used to drive this pump. Pump operational speed (any speed) is reached only if motor torque is greater than pump operating torque. See side figure. Operating Torque (Nm) is given by

Operating Torque = $9549 \times \text{kW (absorbed at operating speed)} / \text{RPM (nominal)}$ According to the centrifugal pump starting, there could be

three principal cases each with his characteristic curve of starting (see examples below).

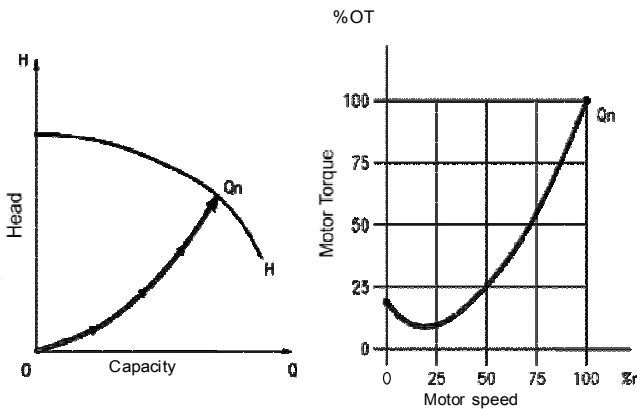
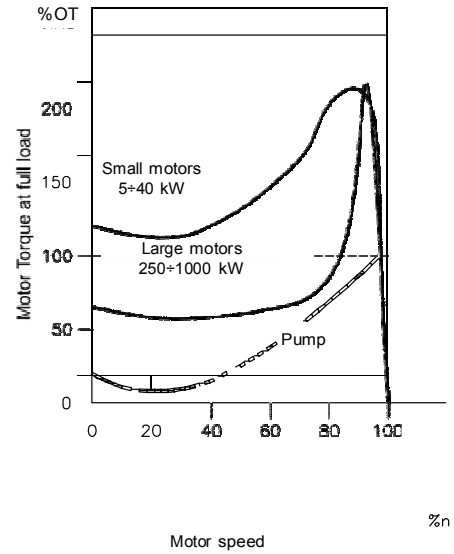

1) Starting with open valve on discharge

During this starting it can be assumed the curve of Operating Torque in function of the round number similar to a parable that starts from about the 20% of the value of Operating Torque to Qn.

2) Starting with partially closed valve on discharge

This type of starting requires a particular observation: first the pump must reach a value of minimum capacity Qm (correspondent to the partialized capacity of the valve) such to guarantee a correct operation without problems of liquid evaporation or excessive radial loads on the shaft; then the pump, by totally opening the valve, will reach the value of nominal capacity Qn and therefore the value of maximum operating torque. NOTE: In this case it is esteemed an absorbed power at the value of Qm corresponding to about 60% of Qn.

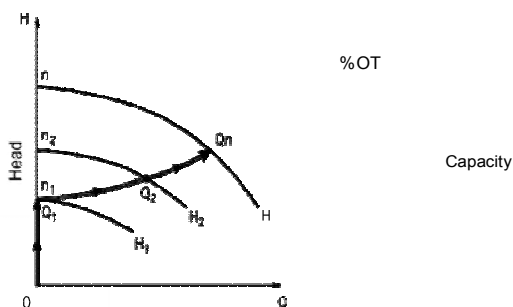
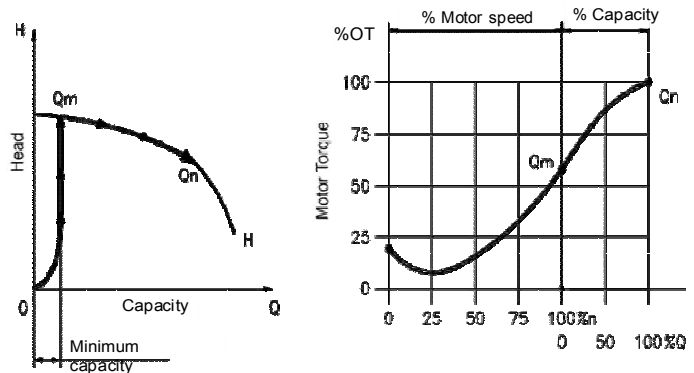

3) Starting with completely open valve and with non return valve on discharge

Motor speed

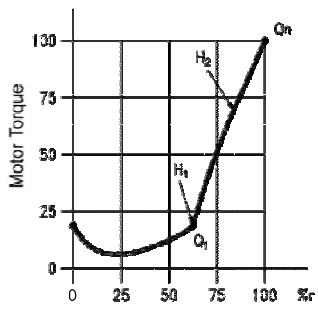

During the starting the non return valve will remain closed up to the attainment of the pressure value **H1** (correspondent to the pre-load pressure of the same valve) and therefore void capacity. This value is reached at speed **n1** (in this example esteemed about 60% of the nominal speed). The continuous motor acceleration will reach the attainment of **Qn** after having passed through **n2**, **Q2**, **H2**.

- TYPICAL PERFORMANCE CURVES

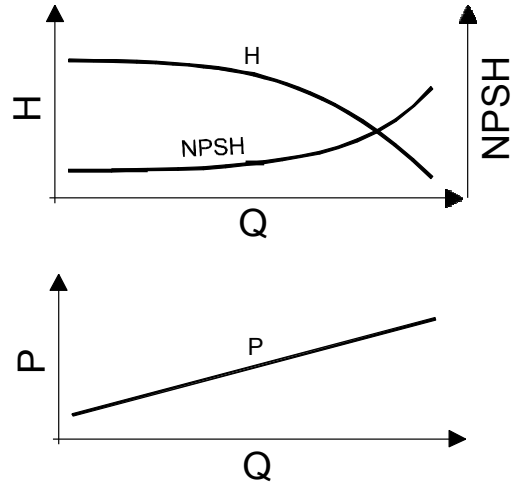

Typical performance curves
for pumps series ACP - TMA

Where:

- H = Head
- NPSH = Net Positive Suction Head
- P = Absorbed power
- Q = Capacity

- UNITS CONVERSION TABLE

	<i>To convert</i>	<i>To obtain</i>	<i>Multiply by</i>	<i>To convert</i>	<i>To obtain</i>	<i>Multiply by</i>
Discharge and Delivery	Litres/sec	Litres/min	60	m ³ /h	Litres/sec	0.2778
	Litres/sec	m ³ /h	3.6	m ³ /h	Litres/min	16.67
	Litres/sec	C.F.M.	2.12	m ³ /h	C.F.M.	0.589
	Litres/min	Litres/sec	0.01667	C.F.M.	Litres/sec	0.4719
	Litres/min	m ³ /h	0.06	C.F.M.	Litres/min	28.32
	Litres/min	C.F.M.	0.0353	C.F.M.	m ³ /h	1.698
Capacity	<i>To convert</i>	<i>To obtain</i>	<i>Multiply by</i>	<i>To convert</i>	<i>To obtain</i>	<i>Multiply by</i>
	Litres	m ³	0.001	U.S. Gal	Litres	3.785
	Litres	Ft ³	0.0353	U.S. Gal	m ³	0.003785
	Litres	U.S. Gal	0.02641	U.S. Gal	Ft ³	0.0133
	Litres	Imp. Gal	0.219	U.S. Gal	Imp. Gal	0.0832
	m ³	Litres	0.001	Imp. Gal	Litres	4.545
	m ³	Ft ³	35.3	Imp. Gal	m ³	0.004545
	m ³	U.S. Gal	264.17	Imp. Gal	Ft ³	0.16
	m ³	Imp. Gal	219.96	Imp. Gal	U.S. Gal	1.2
	Ft ³	Litres	28.32			
Ft ³	m ³	0.0283				
Ft ³	U.S. Gal	7.48				
Ft ³	Imp. Gal	6.228				

	<i>To convert</i>	<i>To obtain</i>	<i>Multiply by</i>	<i>To convert</i>	<i>To obtain</i>	<i>Multiply by</i>
Linear measure	cm	inches	0.3937	inches	cm	2.54
	cm	m	0.01	feet	m	0.3048
	m	feet	3.28084			
	m	cm	100			

NOTES

PUMP model	Serial Number	Computer Number	Year of manuf.
.....

LIQUID handled	Capacity	Suction Pressure	Discharge Press.	Temperature
..... m ³ /h m m °C
<input type="checkbox"/> Lethal	<input type="checkbox"/> Toxic	<input type="checkbox"/> Noxious	<input type="checkbox"/> Corrosive	<input type="checkbox"/> Irritant
<input type="checkbox"/> Clean	<input type="checkbox"/> Dirty	<input type="checkbox"/> With suspended parts	Spec. Gravity.....	Viscosity.....
			Malodorous	PH.....

TOTAL WEIGHT

.....KGs

MAXIMUM DIMENSIONS

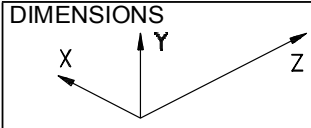

X = cm

Y = cm

Z = cm

NOISE (measured at 1 m)

Pressure =

dB(A) Power = dB(A)

INSTALLATION

Inside Outside

SERVICE

Continuous Intermittent

Explosive area

.....

.....

MOTOR type /Frame	No Poles	No RevolutionsRPM	Absorbed powerAm	Installed PowerkW /.....
FrequencyHz	SupplyVol	Enclosure IP.....	Insulation class	Absorbed PowerkW /..... HP

COMMENTS

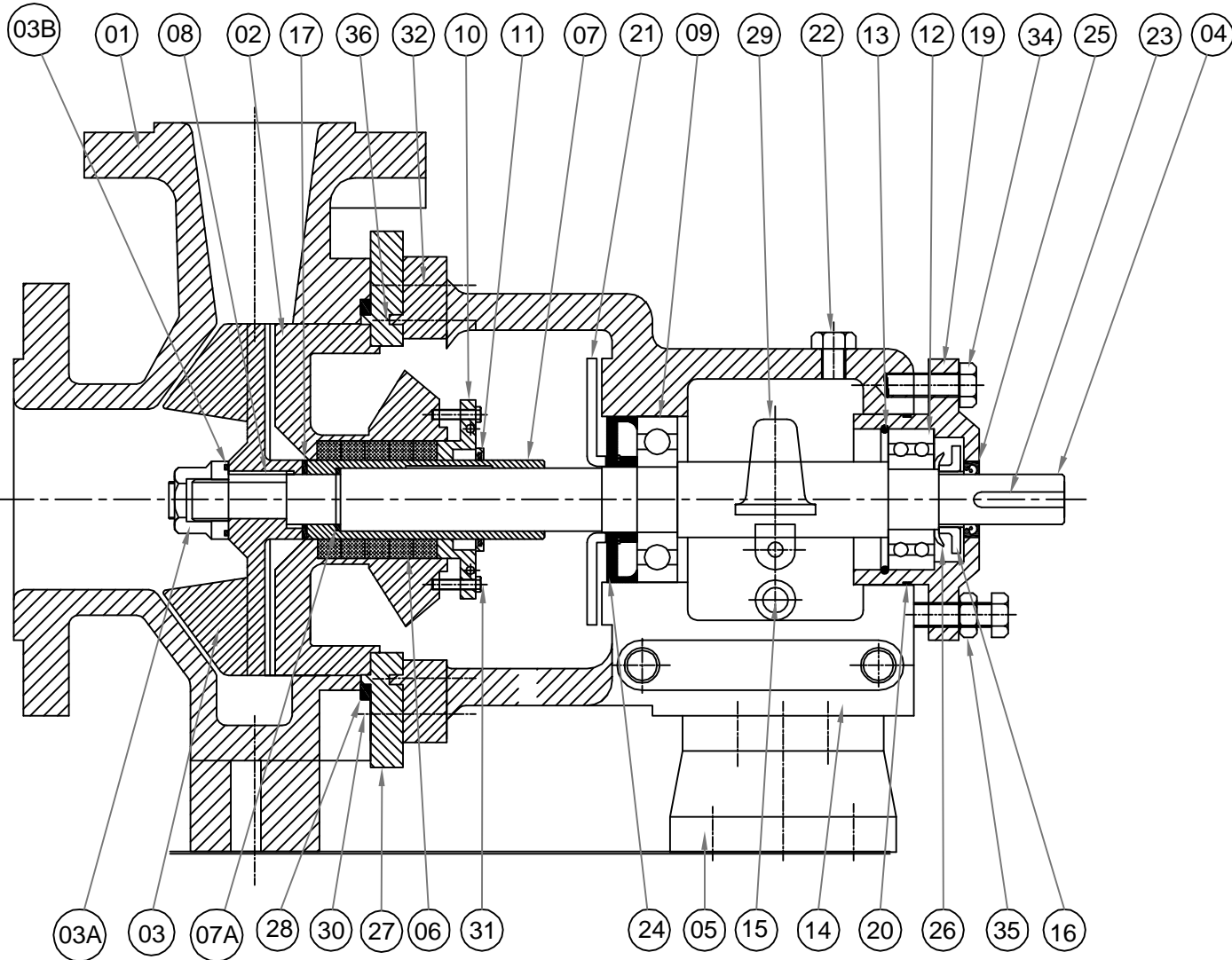

CROSS SECTIONAL VIEW FOR . PUMP (GLAND PACKING ARRANGEMENT)

--	--

PUMP MODEL :	
PUMP SIZE :	
M.O.C :	

Part No.	Description	M.O.C.	Qty Reqd.
36	Bolt-Adpt to brg Frame	Steel	4No.
35	Bolts/jam Nut-Impeller Adj.	Steel	3No.
34	Bolt-Brg Cover to Brg Frame	Steel	3No.
32	Bolt-SBCvr to Bearing Frame	S.S. 316	2No.
31	Stud/Nut-SBCvr to Gland	S.S. 316	2No.
30	Stud/Nut-Casing	S.S. 316	6-8
29	Constant Level Oiller	Poly/Alu	1No.
28	Gasket Casing to St.Box Cover	PTFE	1No.
27	Adapter Ring	Cast Iron	1No.
26	Bearing Lock Washer	Steel	1No.
25	Oilseal Outboard (22x32x7)	Buna Rubber	1No.
24	Oilseal Inboard (30x72x8)	Buna Rubber	1No.
23	Key-Coupling	S.S. 316	1No.
22	Oil Breather	Steel	1No.
21	Deflector	S.S. 304	1No.
20	O - Ring	Buna Rubber	1No.
19	Bearing Cover	Cast Iron	1No.
18	-	-	-
17	Impeller Seal Ring	PTFE	1No.
16	Bearing Lock Nut	Steel	1No.
15	Bearing Oil Drain Plug	Steel	1No.
14	Bearing Frame	Cast Iron	1No.
13	Retaining Ring/Circlip	Steel	1No.
12	Bearing Outboard (3305)	Steel	1No.
11	Gland Pusher Ring	PTFE	1No.
10	Gland Pusher	CF8M	1No.
09	Bearing Inboard (6306)	Steel	1No.
08	Impeller Key	S.S. 316	1No.
07A	Sleeve Gasket	PTFE	1No.
07	Shaft Sleeve	CF8M	1No.
06	Stuffing Box Packing	TIWA	1Set
05	Support foot	Cast Iron	1No.
04	Shaft	CF8M	1No.
03B	Impeller Nut Gasket	PTFE	1No.
03A	Impeller Nut	CF8M	1No.
03	Impeller	CF8M	1No.
02	Stuffing Box Cover/Back Plate	CF8M	1No.
01	Casing	CF8M	1No.
Part No.	Description	M.O.C.	Qty Reqd.