

**SG Series**

**USER MANUAL  
'SG' Series  
Self priming non clog pump**

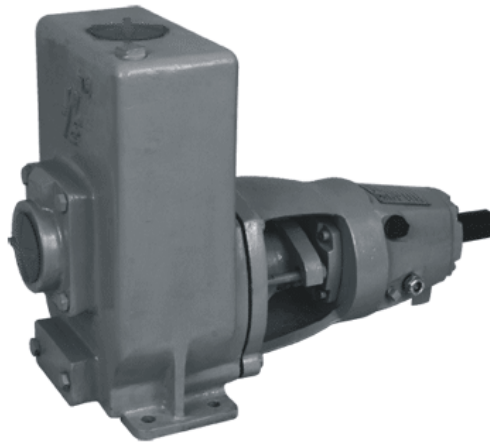

**WEL-TECH EQUIPMENTS**

Plot No. 57/9, Ph-I, G.I.D.C. Vatwa,  
Ahmedabad, Gujarat, India, 382 445

Ph. No. (079) 32917873, 9725053846

E-mail: [ramolia@satyam.net.in](mailto:ramolia@satyam.net.in)

[info@weltechpumps.com](mailto:info@weltechpumps.com)

Web : [www.weltechpumps.com](http://www.weltechpumps.com)

## **Table of contents**

### **Introduction**

Preface  
General information and safety  
Warranty  
Service and support  
Inspection of delivered items  
Lifting  
Storage

### **General**

Pump description  
Construction

- Connections
- Pump casing
- Impeller
- Shaft sealing
- Bearing bracket

Self priming action  
Explanation of designation  
Application area

- Application guidelines

### **Installation**

Safety  
Flushing  
Environment  
Mounting  
Installation of the set  
Assembly  
Alignment of the coupling

### **Commissioning**

Precautions before commissioning  
Preparation lubrication  
Preparing the unit for commissioning  
Checking the sense of rotation  
Preparations start-up  
Startup procedure

- Temperature
- Noise emission
- System pressure

Stop procedure  
Control  
Installation guidelines for pump piping

### **Maintenance**

Precautionary measures  
Daily maintenance  
Periodic inspection



**WELTECH  
EQUIPMENTS PVT LTD**

Innovative Pumping Solutions,  
Reliable Products, Trustworthy  
Designs, Hassle-Free Systems



---

## SG Series

- Flushing
- Ball bearings
- Electrical installation
- Oil seal
- Impeller
- Assembly and disassembly
  - General
  - Replacing the impeller
  - Disassembly impeller
  - Impeller assembly
- Replacement of bearings
  - Disassembly of the ball bearing
  - Assembly of the ball bearing
- Motor replacement
  - Motor disassembly
  - Motor assembly
- Environmental influences
- Cause of failure**
- Trouble shooting
- Fault finding chart
- Possible causes
- Technical data**
- Technical specifications
- Interchangeability chart for 'SG' series
- Pump parts**
- Sectional drawing 'SG' series
- Part list
- Pump disassembly**

## Introduction

### *Preface*

This manual provides the information for proper functioning and maintenance of the pump and contains instructions to prevent possible accidents and damages and to ensure the safe and smooth functioning of the pump.

Before commissioning of the pump, read the manual carefully and strictly follow the instructions.

### ***General information and safety instruction***

The product supplied by WELTECH has been designed with safety in mind.

- Pump installation area must be kept clean and free of obstructions that may restrict safe access to the controls and maintenance access point
- The pump nameplate is fitted to each unit must not be removed. Loss of it could make identification impossible which in turn could cause difficulty in obtaining spare parts. If accidental loss occurs, contact WTE immediately.
- Access to the equipment should be restricted to the personnel responsible for installation, operation and maintenance and they must be trained adequately qualified and supplied with appropriate tools for their respective tasks.
- All personnel that are responsible for installation-operation-maintenance of the pump must study the product instruction manual before any work is done and that they will comply with all local and industry based safety instructions and regulations.
- Safety glasses or goggles should be worn where working with pressurized systems and hazardous substances. Other personal protection equipments must be worn where local rules apply.
- Do not wear loose clothing or jewelry which could catch on the controls or become trapped in the equipments.
- Read the instruction manual prior to installation and confirm that the manual is relevant copy by comparing pump type on the nameplate and with that on the manual.
- Note the 'limits of product application and permissible use' specified in the manual. Operation of the equipment beyond those limits will increase the risk from hazardous and may lead to premature hazardous pump failure.
- Clear and easy access to all controls, gauges, and dials etc. must be maintained at all the times.
- Hazardous or flammable material must not be stored in pump rooms unless safe area or racking and suitable containers have been provided.
- Improper installation, operation or maintenance of this WTE product could result in injury or death.

## SG Series

### **Warranty**

WTE warrants the pump supplied by us is free from defective material and faulty workmanship. This warranty holds good for a period of 12 months from the date of commissioning of the pump or 18 months from the date of dispatch from our factory, whichever is earlier. Our liability in respect of any complaint is limited to replacing part/parts free of charge. Ex-works or repairs of the defective part/parts only to the extent that such replacement/repairs are attributable to our arise solely from faulty workmanship or defective material.

This warranty holds good only for the products manufactures by us.

### **Service and support**

This manual is intended for technicians and maintenance staff and for those who are in charge of ordering spare parts.

This manual contains the spare and replacement parts recommended by WEL-TECH EQUIPMENTS.

The pump sr.no and model number is stated on the nameplate. Please refer to this number and the other data mentioned on the nameplate when corresponding or ordering parts.

### **Inspection of delivered items**

- Check the consignment immediately on arrival for damage and conformity with the advice note.
- In case of damage and/or missing parts, have a report drawn up by the carrier at once.

### **Lifting**

If a pump or a complete pump unit has to be lifted, the slings should be fixed as shown in **figure 1**.

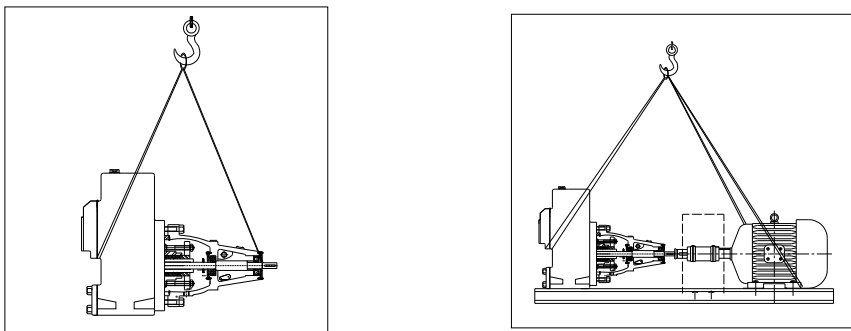

**Figure 1** Lifting instruction pump set SG

## SG Series

**Note: Proper care should be taken to protect pump and prime mover and/or paint at contact area of sling or rope at the time of lifting.**

### **Storage**

In case the pump is not immediately being used, the pump shaft has to be rotated manually twice a week.

## General

### **Pump description**

“SG” Pump is self priming centrifugal pump with volute and radial impeller, mounted overhung on the bearing pedestal. If a spacer type coupling is used, the pump can easily be dismantled without it being necessary to disturb the piping or to move the motor or engine.

A lot of parts of these pumps are interchangeable with those of other pump types from this series.

### **Construction**

#### *Connections*

Suction and delivery connections have the same size.

- From G 1 ¼” to 2 ½” (65 mm): internal Whit worth pipe thread
- From 80 to 150 mm: flanges, pressure stage : 10 bar

#### *Pump casing*

- Volute design with generously sizes casing with water reserve.
- Window cover for draining and cleaning the pump.
- Filler plug G ¾” on top of the pump casing.

#### *Impeller*

Low pressure pumps: semi-open radial 3 or 4 blade centrifugal impeller

High-pressure pumps: closed impeller

#### *Stuffing box*

Heavy duty soft gland packed stuffing box with sufficient deep provides minimum leakage.

## SG Series

### *Bearing bracket*

- For the whole series there are only four different bearing bracket groups.
- Brackets are fitted dustproof, grease-packed deep groove or angular contact ball bearing and require no re-greasing .
- Provision for oil lubrication is also available.
- On the pump side. The bearing housing is sealed with an oil seal.

### *Self priming action*

“SG” pumps are of the self priming type. The self priming action relies on the principle of injection. The pump has to be filled with liquid once. When it has been switched on, the air (of gas) is evacuated from the suction line. The aspirated air is mixed with the liquid contain in the impeller. Through the centrifugal force the liquid/air mixture from the volute flows to the upper half of the pump casing. In the generously sized pump casing the liquid can be deaerated. The air escapes to the discharge line. This causes the liquid to return to the volute (with some pumps the flow back through the impeller inlet) Where it is aerated and then de-aerated again in the upper part of the pump casing.

The air is evacuated from the suction line and the liquid level in this piping rises. Once all air has been evacuated, the pump starts working as a normal centrifugal pump. A precondition for good functioning is that it should be possible for the aspirated air to escape without back pressure in the discharge line (open valves!)

The pump has a non return valve, so the suction and discharge lines can not be siphoned empty, when the pump has been stopped. The remaining liquid in the pump is always sufficient for the next suction phase.

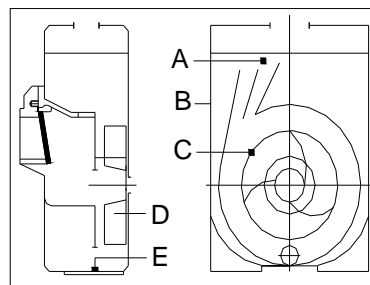

**Figure 2** Self priming action

A: Water / air separation  
D: impeller

B: Pump casing      C: volute  
E: Back flow opening.

## SG Series

### ***Explanation of Designation***

#### *Material Designation*

<b>Part</b>	<b>Material</b>
Pump casing	C.I or Bronze
Impeller	C.I,S.S Or Bronze
Stuffing box	C.I or Bronze
Pump shaft	S.S or EN8
Gland packing	PTFE+ASBESTOS

### ***Application area***

SG pumps used for:

- Clean, contaminated and low viscosity liquids
- The maximum particles size of the impurities depends on the pump impeller size (see 'Technical' specification)
- capacities up to 250m<sup>3</sup>./Hr.
- Delivery heads up to 35 m
- Max. suction head up to 7.5 m
- Viscosities up to 150 mPas
- Max.solid handling size:41mm

In pumping viscous liquids, you should allow for a decrease in hydraulic performance and an increase in power. Please ask our advice.

### ***Application guide lines***

- Draining building excavation.
- Emptying ponds, ditches and swimming-pools.
- Aboard ships as bile, deck wash and general service pumps.
- Emptying pits and troughs contains waste water.
- Handling fuels
- Condensate extraction pumps etc. Please ask our advice.



## Installation

### Safety

- Read this manual carefully before installing and commissioning pump. Non observance of these instructions may cause serious damage to the pump and that will not be covered by our guarantee terms. Follow the instructions step by step.
- Make sure the motor cannot be started when work is done to the pump-motor combination and running parts are insufficiently shielded.
- When installing the pump unit, take appropriate protection and warning measures to prevent contact with hot pump parts.
- If danger arises in case of static electricity. The enter pump unit should be earth properly.
- If there is a danger that the pumped liquid might be harmful to men or the environment, the user should take appropriate measures for safe drainage.
- If there is any risk of liquid solidifying switch off the pump, drain it and preferably flush or fill with oil if permitted.

### Flushing

Before putting the pump in to operation, drain off any preservative agent and flush the pump thoroughly with hot water.

### Environment

- The foundation must be hard, level and flat
- The area in which the pump unit is to be placed should be adequately ventilated. A too high ambient temperature and air humidity, as well as a dusty environment may have a negative effect on the functioning of the pump.
- Around the pump unit there should be enough space to operate and if necessaries repair the pump.
- Behind the cooling air inlet of the motor there should be a free area of at least  $\frac{1}{4}$  of the electric motor diameter, to ensure unobstructed air supply.

### Mounting

#### Installation of the set

Pump and motor shafts of complete sets are adjusted perfectly in line in the works. In case of permanents arrangements place the base plate on the foundation with the aid of shims and tighten the nuts on the foundation bolts carefully.

The check the alignment of pump and motor shafts and realign, if necessary according to the instruction in **Figure 1**.

### Assembly

If the pump and the electric motor still have to assembled, proceed as follows:

1. Mount the two coupling halves on the pumps and motor shaft respectively
2. Place the pump on the foundation slab. Secure the pump with bolts.
3. Place the electric motor on the foundation slab. Between the two coupling halves there should be a gap of 3 mm.
4. Place some copper shims under the feet of the electric motor. Secure the electric motor with bolts.
5. Align the coupling according to the following instruction.

### Alignments of the coupling

1. Place a ruler (A) on the coupling. The ruler should touch both coupling halves across the whole width. See figure 3.
2. Do the same check against both sides of the coupling near the axis.
3. For all security the alignment is also checked with a pair of outside calipers (B) at 2 diametrically opposite points of the side surfaces of the coupling halves. See fig.3

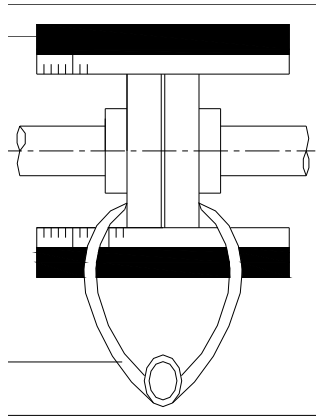

**Figure 3** Aligning of the coupling for SG

### Tolerances for aligning coupling

The maximum allowable tolerances in the alignment of the coupling halves are shown in the table below. See **figure 4**.

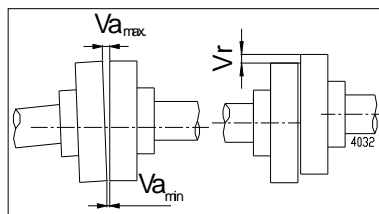

**Figure 4**

## SG Series

Aligning tolerances:

outer diameter coupling (mm)	Va min. (mm)	Va Max (mm)	Va-Va min (mm)	Vr max.
70-80	2	4	0.13	0.13
81-95	2	4	0.15	0.15
96-110	2	4	0.18	0.18
111-130	2	4	0.21	0.21
131-140	2	4	0.24	0.24
141-160	0	6	0.27	0.27

### Piping

- The piping to the suction and delivery connections must fit exactly and must not be subject to stress during operation.
- The passage of the suction pipe must be amply dimensioned. This pipe should be as short as possible and run towards the ump in such a way that no air pockets can arise. If this is not possible, a venting facility should be provided at the highest point of the pipe.
- If the inside diameter of the suction pipe is larger than the suction connection of the pump, an eccentric reducer should be applied to prevent air pockets and whirls.
- If there is a risk that this pressure might be exceeded, for instance because of an excessive inlet pressure, appropriate measures should be taken by mounting a safety valve in the piping.
- Sudden changes in the rate of flow can lead to high pressure impulses in the pump and the piping (water shock). Therefore, don't use quick acting closing devices, valves etc.
- It is advisable to install a foot valve when a suction line is long one or static suction lift is high.
- It is not advisable to have common suction pipe for two or more pumps and similarly two or more suction lines from different sources. Select the suction line diameter as function of its length. It must not be smaller than the pump suction connection, it should also not be too oversized for self priming pump, foot valve is not required unless suction line is too voluminous or the operating conditions are so favorable that suction time is longer than approximately 8 minutes.

### Mounting accessories

- Mount any parts that may have been supplied separately.
- If the liquid does not flow towards the pump, mount a foot valve at the bottom of the suction pipe. If necessary, combine this foot valve with a suction strainer to prevent impurities from being drawn in.
- When mounting, place temporarily (for the first 24 operating hours) fine gauze between suction flange and suction pipe so as to prevent internal parts from

## SG Series

being damaged by foreign matter. If the risk of damage continues to exist, mount a permanent filter.

### Commissioning

#### *Precaution before commissioning*

##### **Pump**

- Check whether the shaft turns freely. Do this by turning the shaft end at the coupling a few times by hands.

##### **Motor**

If driven by an electric motor:

- Check whether the fuses have been mounted.

##### **Engine**

If driven by a combustion engine:

- Check whether the room in which the engine is placed is well ventilated.
- Check whether the exhaust of the engine is not obstructed.
- Before starting the engine check the oil level
- Never turn the engine in a closed room.

#### *Preparation of lubrication*

Fill the recommended oil through the oil filling orifice for detail see start up procedure in seal chamber as per the quantity written on the attention plate.

#### *Preparing the unit for commissioning*

Proceed as follows both when the unit is put in to operation for the first time and after the pump has been overhauled:

1. Fully open the stop valve in the suction pipe. Close the delivery stop valve.
2. Fill the pump and the suction pipe with the liquid to be pumped. Through the priming plug (116) until the liquid starts to over flow.
3. Turn the pump shaft a few times by hand and add more liquid, if necessary.

#### *Checking the sense of rotation*

- The sense of rotation of the pump is indicated by an arrow. Check whether the sense of rotation of the motor corresponds with that of the pump.
- Let the motor run for only a short time and check the sense of rotation.
- If the sense of rotation is not correct, change connecting wire of motor so as to match with the rotation of pump.
- Mount the coupling guard.

## SG Series

### ***Preparations start-up***

Take the following precautions:

1. Before commissioning the pump, remove any presentative and flush the pump with hot water (not more than 60'c).
2. Check whether the oil seal chamber is filled with oil. If not, fill with lubricant.
3. Never arrow the seal to turn dry.
4. Check whether the pump shaft turns freely. Do this by turning the shaft end a few times by hand.
5. Fill the pump with water or the liquid to be handled through the filling plug plug on top of the pump until the liquid starts to over flow.
6. If oil must not come in to contact with the liquid to be pumped, drain out the oil, rinse out the oil chamber and fill with a suitable liquid.

If the pump is supplied with a bare shaft end, the user is responsible for the drive and the assembling with the pump.

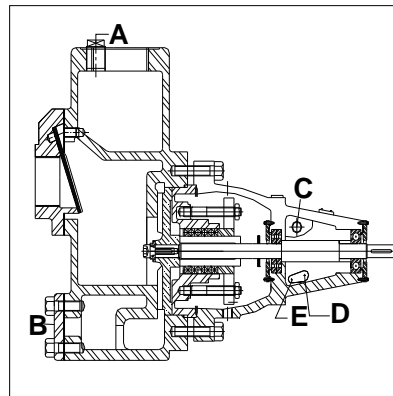

***Figure 5***

- |                              |  |
|------------------------------|--|
| A: Pump housing filling hole | B: Pump housing filling cleaning cover and drain |
| C: Oil chamber filling hole  | D: Oil chamber drain hole                        |

### ***Startup Procedure***

1. Check whether it is safe to put the pump in to operation. Make sure any risks to persons and environment (high pressure, hot temperature, leakage) are absolutely excluded.
2. A protective cover which completely encloses the coupling must always be used.
3. Start the pump.
4. During the pumps self priming phase, ensure the air can escapes unhindered and, without any back pressure in the discharge pipe, can flow away.
5. In particular, make sure any pressure cut-off valves are open.
6. Check if connections and seals are not leaking.

---

## **SG Series**

---

### *Temperature*

The temperature of the pumped liquid may rise to 95 deg. C. above 70 deg. C, the installer of the pump **MUST** place the necessary warnings and employ the necessary protection methods to avoid anyone coming in to contact the pump body.

### *Noise Emission*

1. The noise emission of the SG pump is 80 dBA maximum, measured according to ISO 2372, in case the pump is used in accordance with the conditions given in the performance curve.
2. If the pump is used in unusual condition (e.g. in the cavitation zone or wholly above the curve), the noise level can rise to 85 dBA. And protection measures must be taken, such as the wearing of ear protectors, or completely encasing the pump within a sound absorbent shield.

### *System pressure*

The maximum system pressure = maximum working pressure, given on the technical data sheet. If the pressure could exceed this valve (through an increase in the rotation speed) a safety valve should be installed in the pipe. Where these pumps liquid with solid components, there is a great chance that this valve will block.

It is therefore very much to be preferred **NEVER** to allow the pump to run faster than specified in the tables.

If no fluid is pumped, leaking appear or if excessive noise is apparent, the pump must be stopped immediately, refer section cause of failure to determine the problem. Correct before restarting the pump. If abnormal symptoms persist, the pump must be taken out of service immediately. Contact us or our appointed agents.

### **Stop Procedure**

1. Turn of the motor.

Always avoid restarting the pump during the emptying phase.

During this procedure, the pump is running in the opposite direction. Restarting it can result in the impeller coming loose and being damaged and can even cause breakage of the shaft.

2. If there is any risk of freezing, switch off the pump, drain it and preferably flush or fill it with oil, if permitted It is also recommended to drain the main piping (suction and discharge lines).

---

## SG Series

### ***Control***

If a pump is in operation pay attention to be following:

- The pump should never run dry.
- Never use a stop valve in the suction pipe to control pump capacity. The stop valve should always be fully opened during operation.
- Check whether the absolute inlet pressure is sufficient, so that no vapour can be formed.
- Check whether the pressure difference between suction and delivery pressure corresponds with specifications for the duty point of the pump.

**SG Series**

**Installation guidelines for pump piping**

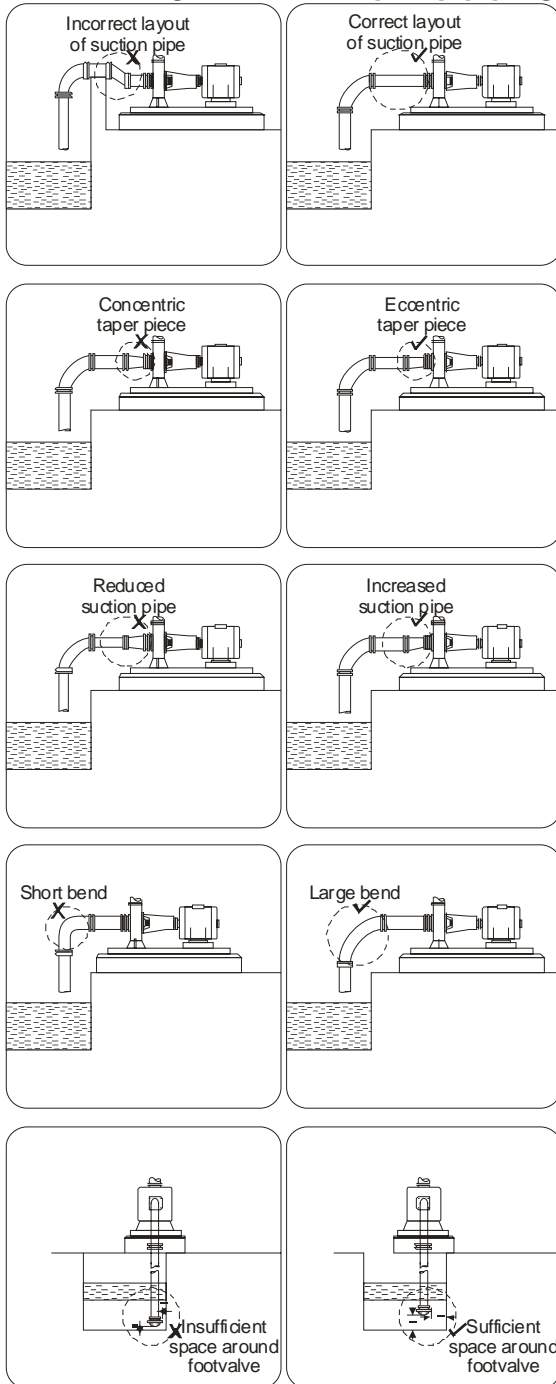



## Maintenance

### *Precautionary measures*

- Insufficient, wrong and/or irregular maintenance can lead to malfunctions in the pump, high repair costs and long term inoperability. Therefore you should carefully follow the guidelines given in this chapter during maintenance operations on the pump. Non compliance with prescriptions or warnings may be dangerous for the user and/or seriously damage the pump/pump group.
- All work should be carried out by suitable trained personnel.
- Pump and piping may contain high pressure liquids, high temperature liquids or/and hazardous chemical fluids even when the unit has been shut down. Before dismantling, always allow the pump to cool (20°C) and allow it to drain completely.
- Ensure that the working area is clean, because certain parts such as the mechanical shaft seals are extremely vulnerable and others have very close tolerances.
- In case of storage:
  - ◆ The pump must be operated briefly once a week or alternatively one manually makes a full revolution of the pump shaft.
  - ◆ This ensures a proper circulation of the protective oil.

### *Daily Maintenance*

- Keep both the surface of the pump and the surrounding as clean as possible. This simplifies inspection (attached marking remain visible).
- Never spray the hot parts of a pump with water; as certain components may crack due to the sudden cooling and fluid being pumped may spray in to the environment.

### *Periodic inspection*

- The pump should run smoothly and free from noise or vibration
- Shaft alignment and levelness of the base plate
- Gasket joints at pump casing and seal cover and suction / discharge connections should be inspected for leak.
- Make sure appropriate grade and amount of lubricant is present in bearings and in the oil chamber .
- Check bearing for excessive wear. Wrong bearing may result in excessive shaft run-out necessitating frequent seal future.
- Always ensure that the liquid level in the suction line is adequate. Never allow the suction head to drop below the minimum NPSH (required) by the pump.

### *Flushing*

Because the pump could have been used for corrosive or poisonous liquids, it should first be thoroughly rinsed out. Flushing the pump out is necessary because the origin of

---

## SG Series

---

the liquid which it contained is not always known and, even after draining the pump liquid can remain inside.

- Present connections can be used to flush the pump out.
- During this flushing procedure, observe adequate safety regulations and take environmental protection measures. The wearing of gloves and safety glasses to protect against possible splashes and hot temperature is advised.

### ***Ball Bearing***

The ball bearing are sealed and packed with grease, relubrication is not necessary. The life time of the bearing of the most heavily loaded pump is approx. 10,000 running hours, and for the lightest loaded pump it is approx. six times longer. The lubrication of the bearing plays a very important role and therefore it is recommended to replace the bearing after 10,000 hours of service, or every three years.

### ***Electrical installation***

Maintenance operations on the electric installation may be performed only by trained and qualified personnel and after disconnecting the electric power supply. Carefully follow the national safety regulations. Respect the above mentioned regulations also if performing work while the power supply is still connected.

### ***Stuffing box packing***

After the pump is started, the stuffing box will show a certain amount of leakage. Because of the expansion of the packing fibers, this leakage will gradually decrease. Make sure that the packing never runs dry. To prevent this, loosen the gland nuts to the extent that the stuffing box leaks drop wise. As soon as the pump has reached the proper temperature (and leakage is still too much) the gland can be adjusted permanently.

- Tighten both gland nuts, one after the other, a quarter turn.
- Wait 15 minutes after each adjustment before making the next adjustment.
- Continue in this way until an acceptable drop wise leakage has been attained.(20-30 drops/minutes)

### ***Impeller***

If there is decline in the performance characteristics of the pump when neither the installation nor the working point has been changed it is 90% certain that there is wear on the impeller. How quickly this wear occurs is dependent upon the type of liquid being pumped. There is a clearance between the impeller and the pump casing. This clearance becomes greater through wear. In order to check this, the pump must be dismantled and the dimensions A as shown in figure 7 should be measured. It must not exceed 0.5 mm.

## SG Series

The dismantling and re-assembly instruction are given in the following points.

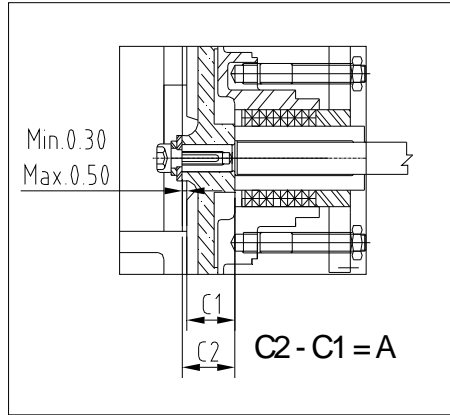

**Figure 7**

### **Assembly and Disassembly**

#### *General*

- When the servicing the pumps, see to a clean working environment because certain parts, say, the mechanical seal, are extremely vulnerable, other part having close tolerances. Check that the parts have not been damaged in transit. In particular, inspect the spigots mating and sealing faces, etc.
- Loctite liquid securing type 243 in used for securing the impeller screw or impeller bolt.
- When Loctite is used, first degrease the parts properly. The Loctite must be applied in sufficient Quantities both internally and the bolts tightened up to the torque settings shown in table below :

Material bolt	Max. tightening torque Nm.					Application
	M-6	M-8	M-10	M-12	M-16	
8.8	11	25	51	87	215	Bearing bracket Internal piece.
A2 / A4	8.5	21	42	70	173	Impeller

#### *Replacing the impeller*

Also refer to sectional drawings

### Disassembly impeller

Figure 8

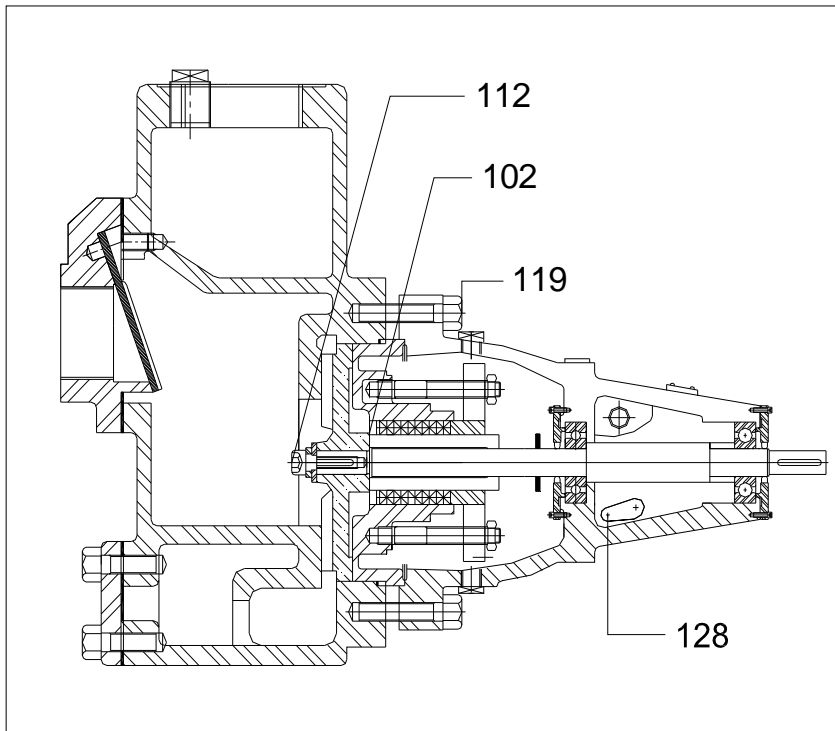

1. Drain out the drain liquid from the oil chamber by removing the oil drain plug (128)
- 2A. Bearing bracket 00, 0 and 0+
  - a) Detach bearing bracket by loosening bolts (119).
  - b) Undo the impeller screw (112).
- 2B. Bearing bracket 1 and 2:
  - a) Detach bearing bracket by loosening bolts (119).
  - b) Disassemble ST.BOX with bearing from pump casing by loosening bolts (119).
  - c) Undo the impeller bolt.
  - d) Remove washer.
3. Next detach the impeller (102) using a coupling puller.

---

## **SG Series**

---

### *Impeller assembly*

1. When pushing on the impeller, accurately check that its position is square with the shaft.
2. When an impeller is assembled with a key (113), neither the key nor the key ways in the shaft or impeller must be adjusted.
3. Insert the same number of gasket between pump casing and intermediate cover, removed during disassembling from factory fitted pump.
4. Slid the impeller in to shaft.
5. Take the washer and fit-depending on the construction of the impeller screw, Allen screw or impeller bolt with washer, using Loctite
6. Next provide the gaskets (108) in the pump casing and fix the bearing bracket to it using the Allen screw.

### **Replacement of the bearing**

The ball bearing is sealed and grease/oil-packed, so they are lubricated for life.

### *Disassembly of the ball bearing*

1. Disassemble the impeller and shaft seal. Please refer to the disassembly instruction
2. Disassembled the ball bearing cover, the inner circlip and the laminated seal.
3. Strike the shaft on impeller side such that the shaft and bearing are released from the bearing bracket.
4. Remove the ball bearing along the shaft end side, using a coupling puller.
5. Remove shoulder rings out of the bearing bracket.
6. Clean the shaft properly on impeller side, particularly where the shaft seal is positioned, then removes the ball bearing on impeller side.

### *Assembly of the ball bearing*

1. Properly clean the ball bearing bores and the shaft length over which the bearing have to be pushed.
2. Put the removed shoulder ring back in to the bearing bracket.
3. Cautiously place the ball bearing on the shaft, In case of the construction, then fit a Nilos ring
4. Fit the outboard bearing from shaft end side.
5. Fit the in board clip.
6. Now push the shaft with two bearings through the bore at the bearing bracket.
7. Fit the out board spring circlip.
8. For the assembly of the shaft seal and impeller please refer to the relevant instruction.

### ***Motor replacement***

Also refer to sectional drawing.

### ***Motor disassembly***

1. Disassemble pump casing from lantern piece loosening bolts (119) (bearing bracket group1 and 2:0770)
2. Disassemble the impeller and shaft seal.
3. Detach the lantern piece from the motor by loosening bolts.
4. Replace motor.

### ***Motor assembly***

1. Start to assemble with the motor. To that effect, position the motor with the shaft pointing upwards.
2. Place the lantern piece on the motor, using the bolts.
3. Now fit the shaft seal and impeller.
4. Use loctite 243 for fitting impeller bolt or impeller nut.

### ***Environmental influences***

- Regularly clean the filter in the suction pipe or the suction strainer at the bottom of the suction pipe, as the inlet pressure may become too low if the filter or the suction strainer is fouled.
- If there is a risk that the pumped liquid expands during solidification or freezing, the pump has to be drained and, if necessary, flushed after it has been put out of service. If the pump is out of service for a long time, it has to be preserved.

### **Cause of failure**

In general, failures in a pump unit are attributable to the following causes.

1. Failure in the pump
2. Failure or faults in the piping system.
3. Failure due to wrong installation or commissioning
4. Failure due to a wrong pump selection.

A number of the most frequently occurring failures as well as their possible causes are set forth in the table below.

### ***Trouble shooting***

In case of abnormal operation or when troubles occur the pump must be taken out of service immediately. Inform all responsible personal, Prior to restarting the pump the cause of the problem must be determined and the problem to be solved.

### ***Fault finding chart***

<b>Most frequently occurring failures</b>	<b>Possible causes.</b>
Failure of delivered liquid	A,B,C,D,E,G
Pump does not deliver rated capacity	A,C,D,E,F,G,H,N,S
Pump does not develop rated pressure	A,E,H,K,M,S
Pump overloads driver	H,L,M,N,O,S,X
Vibration	C,D,K,P,Q,R,S,T,U,V,X
Bearing wear rapidly	Q,T,W,X,Y
Motor heating up	H,O,Z
Seized pump	B,S,F,X
Irregular delivery	D,G,K,P
Pump does not prime	A,B,F,G
Noisy pump	C,D,G,H,P,Q,R,T,U,V,X,Y

### ***Possible causes***

- A. Wrong direction of rotation
- B. Pump not filled with liquid
- C. Inlet or suction pipe insufficiently submerged.
- D. NPSH available too low
- E. Pump not up to rotted speed
- F. Total head greater than rated
- G. air leak in suction line
- H. Viscosity greater than rated
- I. Impeller damaged
- K. Gas or vapor in liquid
- L. Seep to high
- M. Total head lower than rated
- N. Total head higher than rated
- O. Viscosity and/or specific gravity higher than rated
- P. Starved suction
- Q. Misalignment
- R. Worn or loose bearings
- S. Impeller blocked or damaged
- T. Bent shaft
- U. Improper location of discharge valve
- V. Foundation not rigid
- W. Bearing badly installed
- X. Pipes exert forces on pump

## SG Series

- Y. vibration
- Z. Speed too high, check motor name plate.

**IF SYMPTOMS PERSIST THE PUMP MUST BE TAKEN OUT OF SERVICE IMMEDIATELY and Contact us or our appointed agents.**

### Technical data

#### Technical specification

SG SERIES		32-110	40-110	32-160	50-120/A	50-120	65-120	65-150	65-160	80-140
<b>CONSTRUCTION</b>										
Bearing bracket		1	1	2	2	2	2	2	2	2
<b>CONNECTIONS</b>										
Suction and discharge	Rp mm	1 ¼"	1 ½"	1 ½"	2"		2 ½"			DN80
		32	40	32	50		65			DN80
Filling plug pump casing	Rp	¾"	¾"	¾"	¾"	¾"	¾"	¾"	¾"	¾"
<b>CHARACTERISTICS</b>										
Max. working pressure.(PN)	bar	5	5	5	5	5	5	5	5	5
Passage (partial size)	Mm	6	11	5	8	12	19	13	13	18
Max. liquid temperature	Deg.	95	95	95	95	95	95	95	95	95
Max. liquid viscosity	mPas.	150	150	150	150	150	150	150	150	150
<b>BEARING</b>										
Inboard bearing					6305			6305		
Out board bearing					6305			6305		
<b>DRIVE (***)</b>										
Maximum speed:										
Direct drive	Min.-1	3500	3500	3500	3500	3500	3500	3500	3500	3500
Belt drive	Min.-1	2900	2900	2900	2900	2900	2900	2900	2900	2900
Belt min. pump pulley	Mm	250	250	A163	A63	A63	A63	A160	A160	A160
<b>GLAND PACKING</b>										
Sleeve dia.	Mm			35	35	35	35	35	35	35
Gland packing	Mm			10	10	10	10	10	10	10
<b>OIL CHAMBER PLUG</b>										





**SG Series**

Filling and Draining	Rp.	1/4"	1/4"	1/4"	1/4"	1/4"	1/4"	1/4"	1/4"	1/4"
<b>OIL CHAMBER CONTENTS</b>										
(Oil type: 30 Grade)	ml.			300	300	300	300	300	300	300

**Interchangeability chart of parts for "SG" series**

PART No.	PART NAME	PUMP MODEL (SIMILAR NUMBER INDICATES COMMON PART OF RESPECTIVE PUMP)								
		32-110	40-110	50-120A	50-120	32-160	65-120	65-150	65-160	80-140
102	IMPELLER	1	2	3	4	5	6	7	8	9
140	ST.BOX	1	1	2	2	2	2	2	2	2
258	BEA.HSG.	1	1	2	2	2	2	2	2	2
101	PUMP CASING	1	2	3	3	4	5	6	7	8
121	SHAFT	1	1	2	2	2	2	2	2	2
253	SLEEVE	1	1	2	2	2	2	2	2	2
113	IMPELLER KEY	1	1	2	2	2	2	2	2	2
126	SHAFT END KEY	1	1	2	2	2	2	2	2	2
127	OIL SEAL	1	1	2	2	2	2	2	2	2
103	SUC.COVER	1	2	3	3	1	4	4	4	5
105	FLAP VALVE	1	2	3	3	1	4	4	4	5
108	GASKETFOR PUMP CASING	1	1	2	2	2	2	2	2	2
249	GASKET FOR SUC.COVER	1	2	3	3	1	4	4	4	5
250	GLAND PUSHER	1	1	2	2	2	2	2	2	2
251	GLAND PUSHER RING	1	1	2	2	2	2	2	2	2

**SG Series**

**Pump Parts**

**Sectional drawing 'SG'SERIES**

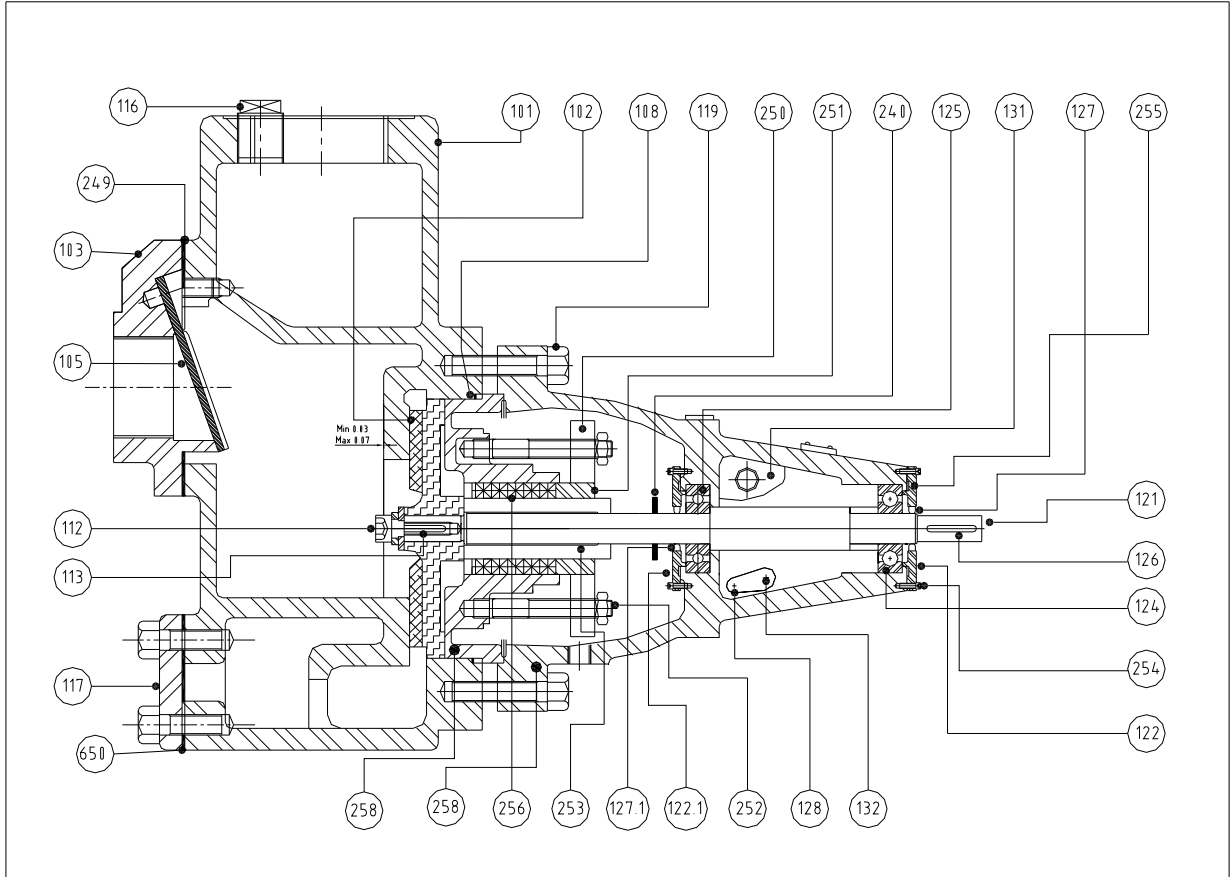

**PART LIST (MODEL-SG)**

SR NO	PART NO	PART NAME	MATERIAL	
1	101	PUMP CASING	CI / SS / BRONZE	
2	102	IMPELLER	CI / SS / BRONZE	1
3	103	SUCTION COVER	CI / SS / BRONZE	1
4	105	FLAP VALVE	NBR+STEEL/PTFE+SS	1
5	108	GASKET FOR CASINGSSS	C.A.F (IT400)	2
6	112	ALL.BOLT+WASHER FOR IMPELLER	STEEL	1
7	113	IMPELLER KEY	STEEL/SS	1
8	116	PRIMING PLUG	STEEL/SS	1
9	117	WINDOW COVER	CI / SS / BRONZE	1
10	119	HEX BOLT	STEEL/SS	10
11	121	PUMP SHAFT	EN8/SS	1
12	122	BEARING COVER (DE)	CI	1
13	122.1	BEARING COVER (NDE)	CI	1
14	124	BEARING (DE)	STD.	1
15	125	BEARING (NDE)	STD.	1



**WELTECH  
EQUIPMENTS PVT LTD**

Innovative Pumping Solutions,  
Reliable Products, Trustworthy  
Designs, Hassle-Free Systems



**SG Series**

16	126	KEY FOR COUPLING	STEEL	1
17	127	OIL SEAL (DE)	NEOPRENE	1
18	127.1	OIL SEAL (NDE)	NEOPRENE	1
19	128	DRAIN PLUG	STEEL	1
20	131	OIL FILLING PLUG	PP	1
21	132	OIL INDICATOR	STD.	1
22	240	DEFLECTOR	RUBBER	1
23	250	GLAND PUSHER	CI / SS / BRONZE	1
24	251	GLAND PUSHER RING	CI / SS / BRONZE	1
25	252	STUD WITH NUT WASHER SET	SS	2
26	253	SHAFT SLEEVE	SS	1
27	254	ALLEN CAP BOLT	STEEL	4
28	255	GASKET (DE,NDE BRG.COVER)	C.A.F (IT400)	2
29	256	GLAND PACKING SET	ASB.+PTFE.	4